



# Unit-2

# Energy Storage Systems

By,  
Mr. A J Bhosale  
Asst. Professor  
Dept. of Automobile Engineering  
Govt. College of Engineering and Research, Avsari (Kd)



## **Syllabus:**

Types of batteries- Lead acid battery, Nickel-based batteries -Nickel Manganese Cobalt (NMC), Nickel Cobalt Aluminum (NCA), sodium-based batteries, and

Lithium-based batteries – Li-ion & Li-poly, Lithium-Cobalt oxide (LCO), Li-ion Manganese Oxide (LMO), Lithium iron Phosphate (LFP), metal-air battery, zinc chloride battery, Ultracapacitors,

Battery-characteristics & parameters, Battery ratings, Battery Performance, Battery capacities, Battery efficiency, Battery tests, Battery failures, Recycling of batteries.

•

## ❖ Battery:-

- An electro-chemical apparatus used for accumulating charge for use at later stage and that's why it also called as “charge accumulator”
- Stores electrical energy in the form of chemical energy and then converts this chemical energy to electrical energy when needed: essentially an electrical energy storage device
- Contains
  - Electrodes (Cathode and Anode)
  - Electrolyte

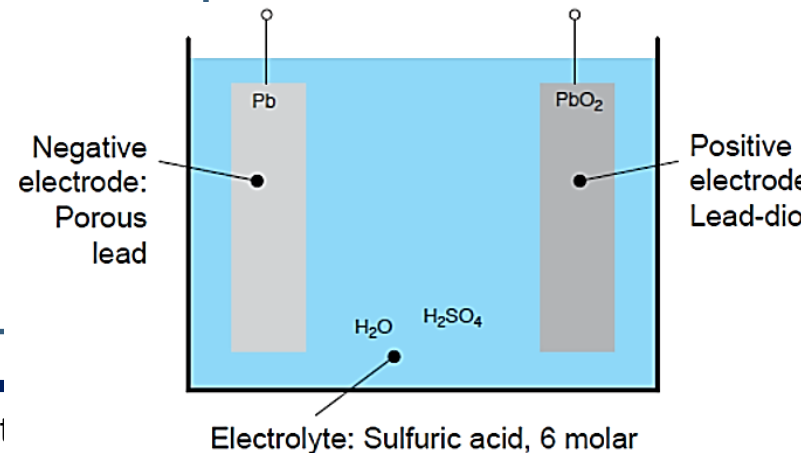
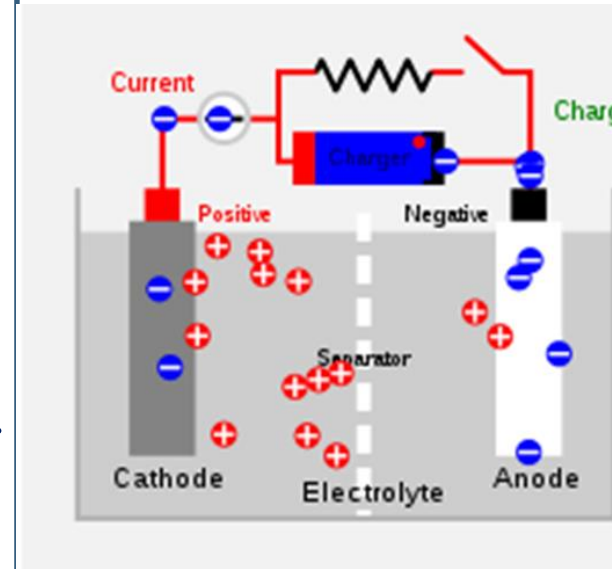



## ❖ Requirements:

- To provide power storage and be able to supply it quickly enough to operate the vehicle starter motor.
- To allow the use of parking lights for a reasonable time.
- To allow operation of accessories when the engine is not running.
- To act as a swamp to damp out fluctuations of system voltage.
- To allow dynamic memory and alarm systems to remain active when the vehicle is left for a period of time.
- The final requirement of the vehicle battery is that it must be able to carry out all the above listed functions over a wide temperature range. This can be in the region of  $-30$  to  $70^{\circ}\text{C}$ .

## ❖ Battery Selection:

- The correct battery depends, in the main, on just two conditions.
  1. The ability to power the starter to enable minimum starting speed under very cold conditions.
  2. The expected use of the battery for running accessories when the engine is not running.
- European standards generally use the figure of  $-18^{\circ}\text{C}$  as the cold start limit and a battery to meet this requirement is selected.

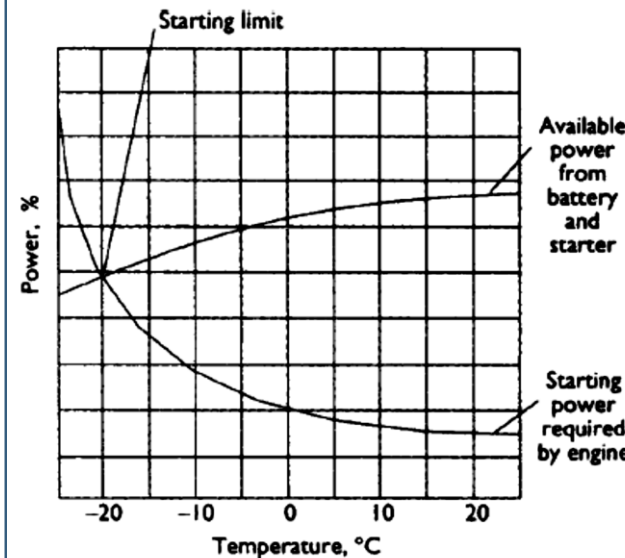

Figure 5.1 Comparison of the power required by the starter and the power available from the battery plotted against temperature



- Research has shown that under ‘normal’ cold operating conditions in the UK, most vehicle batteries are on average only 80% charged.
- Many manufacturers choose a battery for a vehicle that will supply the required cold cranking current when in the 80% charged condition at  $-7^{\circ}\text{C}$ .



## ❖ Positioning The Battery in Vehicle

- Several basic points should be considered when choosing the location for the vehicle battery:
  - Weight distribution of vehicle components.
  - Proximity to the starter to reduce cable length.
  - Accessibility.
  - Protection against contamination.
  - Ambient temperature.
  - Vibration protection.
- As usual, these issues will vary with the type of vehicle, intended use, average operating temperature and so on.
- Extreme temperature conditions may require either a battery heater or a cooling fan. The potential build-up of gases from the battery may also be a consideration.



## ❖ **Battery Types:**

**1. Primary Battery (Disposable Batteries)** capable of converting chemical energy into electrical energy and in this process gets exhausted. The chemical reaction is irreversible.

- Examples:- Zinc carbon (flashlights, toys), Heavy duty zinc chloride (radios, recorders), Alkaline (all of the above), Lithium (photoflash), Silver, mercury oxide (hearing aid, watches), Zinc air.

**2. Secondary Battery (Rechargeable Batteries):** Also called storage cells. Convert chemical energy into electrical energy or vice versa by reactions that are essentially reversible

- Examples:- Nickel cadmium, Nickel metal hydride, Alkaline, Lithium ion, Lithium ion polymer, Lead acid.





<b>Primary Battery</b>	<b>Secondary Battery</b>
Cell reaction is irreversible	Cell reaction is reversible.
Must be discarded after use	May be recharged
Have relatively short shelf life	Have long shelf life
Function only as galvanic cells .	Functions both galvanic Cell & as electrolytic cell.
They cannot be used as storage devices	They can be used as energy storage devices(e.g. solar/thermal energy converted to electrical energy)
They cannot be recharged	They can be recharged
Dry cell.	Lead acid

## Galvanic Cell Vs Electrolytic Cell

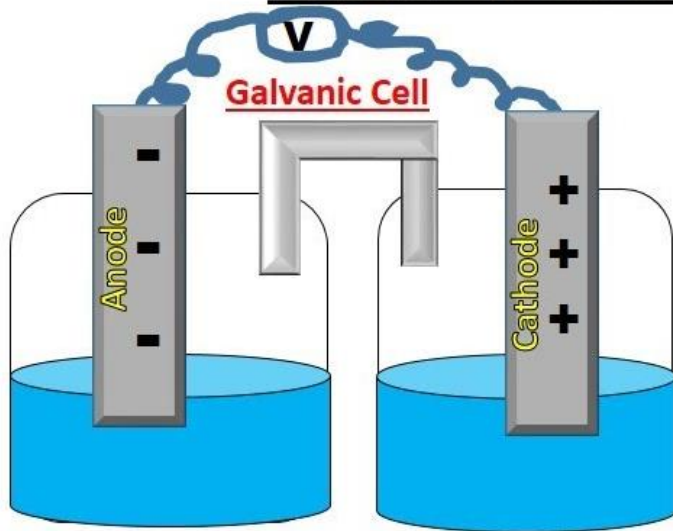

**Changes chemical energy into Electrical energy .**

1. Anode is -ve
2. Cathode is +ve
3. Spontaneous reaction occurs.
4. Does not require external voltage source.

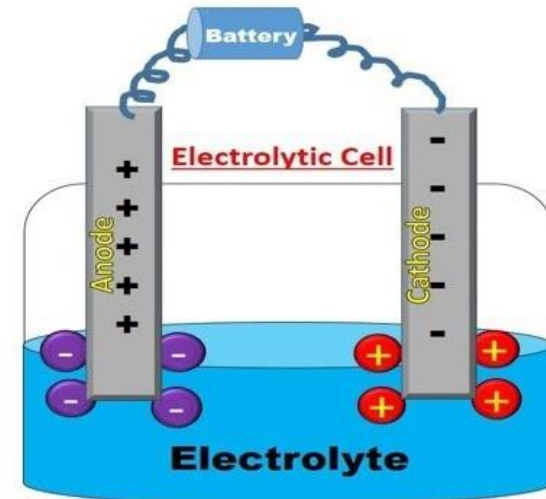

**Changes electrical energy into Chemical reaction.**

1. Anode is +ve
2. Cathode is -ve
3. Non-Spontaneous reaction occurs.
4. Require external voltage source.



## ❖ Working Principle:(Lead Acid Battery)

- The storage battery or secondary battery is such battery where electrical energy can be stored as chemical energy and this chemical energy is then converted to electrical energy as when required.
- The conversion of electrical energy into chemical energy by applying external electrical source is known as **charging of battery**.
- Whereas conversion of chemical energy into electrical energy for supplying the external load is known as **discharging of secondary battery**.
- During charging of battery, current is passed through it which causes some chemical changes inside the battery. This chemical changes absorb energy during their formation.
- When the battery is connected to the external load, the chemical changes take place in reverse direction, during which the absorbed energy is released as electrical energy and supplied to the load.

## ❑ Materials used for Lead Acid Storage Battery Cells

- The main active materials required to construct a lead-acid battery are
  1. Lead peroxide ( $\text{PbO}_2$ ).
  2. Sponge lead ( $\text{Pb}$ ) and
  3. Dilute sulfuric acid ( $\text{H}_2\text{SO}_4$ ).

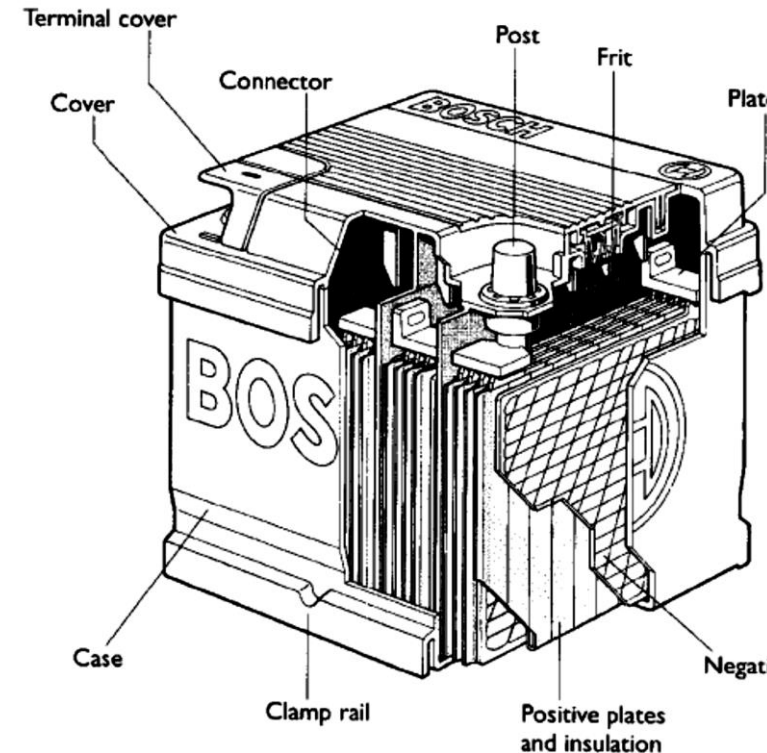
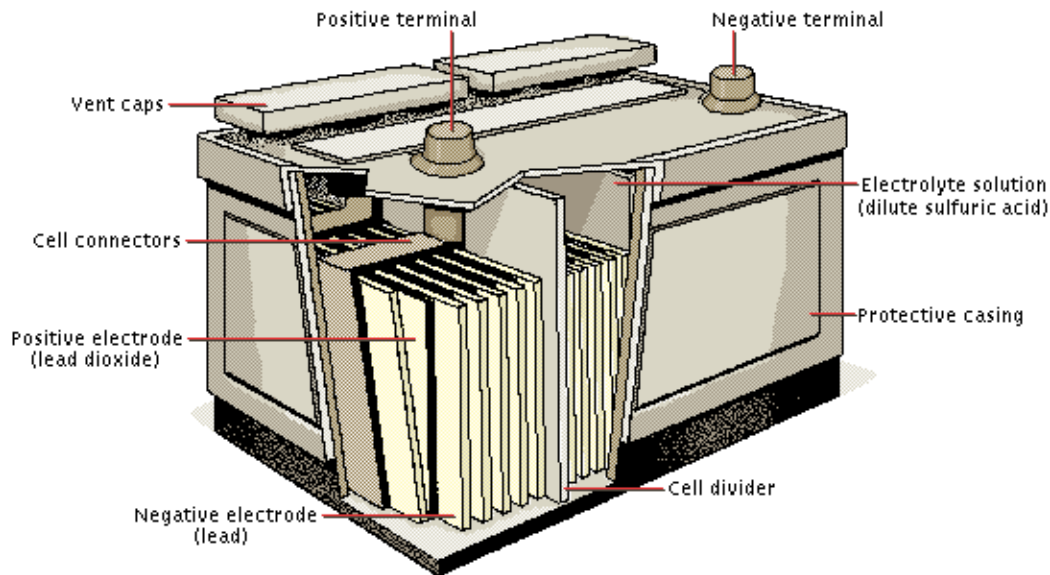



## **Lead Peroxide ( $\text{PbO}_2$ )**

- The positive plate is made of lead peroxide. This is dark brown, hard and brittle substance.

## **Sponge Lead (Pb)**

- The negative plate is made of pure lead in soft sponge condition.

## **Dilute Sulfuric Acid ( $\text{H}_2\text{SO}_4$ )**

- Dilute sulfuric acid used for lead acid battery has ratio of water : acid = 3:1. (65% water and 35%  $\text{H}_2\text{SO}_4$ )
- The lead acid storage battery is formed by dipping lead peroxide plate and sponge lead plate in dilute sulfuric acid.





## ❖ Discharging:-

- Consider a battery is in fully charged condition and a load is connected externally between these plates.
- In diluted sulfuric acid the molecules of the acid split into positive hydrogen ions ( $H^+$ ) and negative sulfate ions ( $SO_4^{--}$ ).
- The hydrogen ions when reach at  $PbO_2$  plate (positive plate), they receive electrons from it and become hydrogen atom which again attack  $PbO_2$  and form  $PbO$  and  $H_2O$  (water).
- This  $PbO$  reacts with  $H_2SO_4$  and forms  $PbSO_4$  and  $H_2O$  (water).



- $SO_4^{--}$  ions are moving freely in the solution so some of them will reach to pure Pb plate where they give their extra electrons and become radical  $SO_4$ . As the radical  $SO_4$  cannot exist alone it will attack Pb and will form  $PbSO_4$ .
- As  $H^+$  ions take electrons from  $PbO_2$  plate and  $SO_4^{--}$  ions give electrons to Pb plate, there would be an inequality of electrons between these two plates. Hence there would be a flow of current through the external load between these plates for balancing this inequality of electrons. This process is called **discharging of lead acid battery**.



- The lead sulfate ( $\text{PbSO}_4$ ) is whitish in color.
- During discharging,
  1. Both of the plates are covered with  $\text{PbSO}_4$ .
  2. Specific gravity of sulfuric acid solution falls due to formation of water during reaction at  $\text{PbO}_2$  plate.
  3. As a result, the rate of reaction falls which implies the potential difference between the plates decreases during discharging process.





## ❖ Charging:

- Now we will disconnect the load and connect PbSO<sub>4</sub> covered PbO<sub>2</sub> plate with positive terminal of an external DC source and PbSO<sub>4</sub> covered Pb plate with negative terminal of that DC source.
- During discharging, the density of sulfuric acid falls but there still sulfuric acid exists in the solution.
- This sulfuric acid also remains as H<sup>+</sup> and SO<sub>4</sub><sup>- -</sup> ions in the solution.
- Hydrogen ions being positively charged, move to the electrode (cathode) connected with negative terminal of the DC source.



- Here each H<sup>+</sup> ion takes one electron from that and becomes hydrogen atom. These hydrogen atoms then attack PbSO<sub>4</sub> and form lead and sulfuric acid.



- SO<sub>4</sub><sup>- -</sup> ions (anions) move towards the electrode (anode) connected with positive terminal of DC source where they will give up their extra electrons and become radical SO<sub>4</sub>.
- This radical SO<sub>4</sub> cannot exist alone hence reacts with PbSO<sub>4</sub> of anode and forms lead peroxide ( PbO<sub>2</sub>) and sulfuric acid (H<sub>2</sub>SO<sub>4</sub>).





- Hence by charging the lead acid storage battery cell,
  1. Lead sulfate anode gets converted into lead peroxide.
  2. Lead sulfate of cathode is converted to pure lead.
  3. Terminal; potential of the cell increases.
  4. Specific gravity of sulfuric acid increases.

**The chemistry of the production of a voltage by a lead-acid battery**

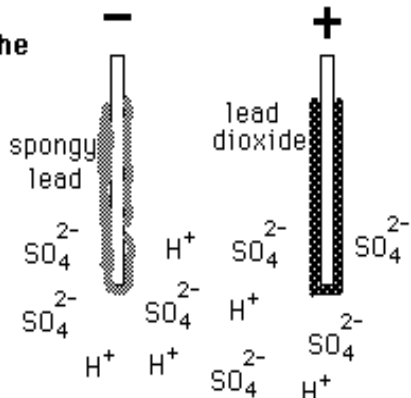

$Pb^{2+} + SO_4^{2-} \rightarrow PbSO_4$   
 Lead electrode must supply positive ions and is left negative

$PbO_2 + H_2SO_4 \rightarrow PbSO_4$   
 Lead dioxide electrode must supply electrons and is left positive

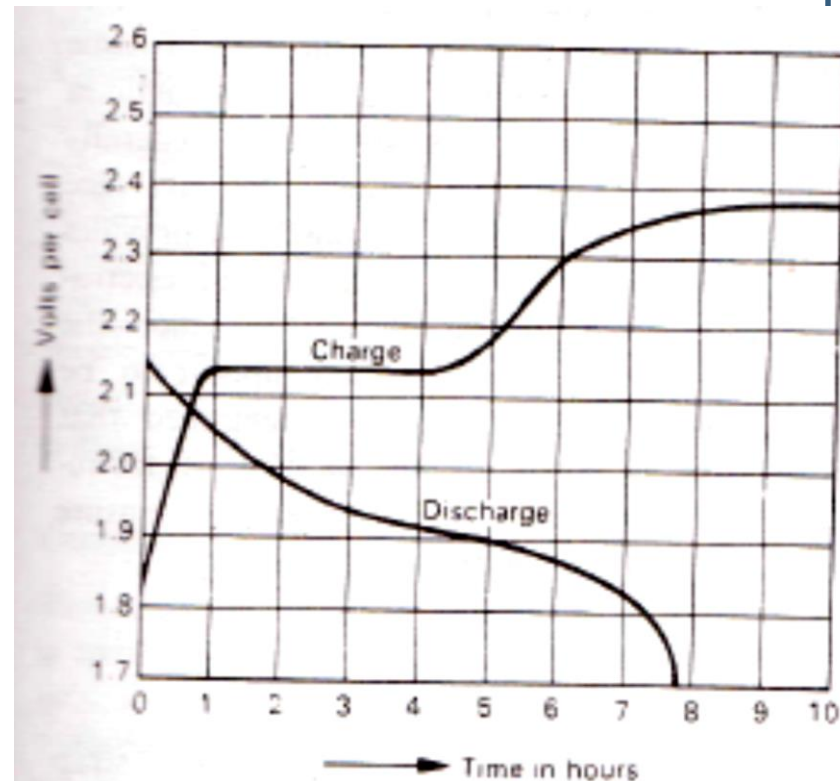
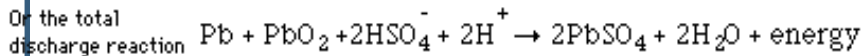
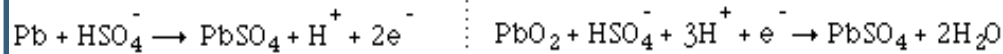

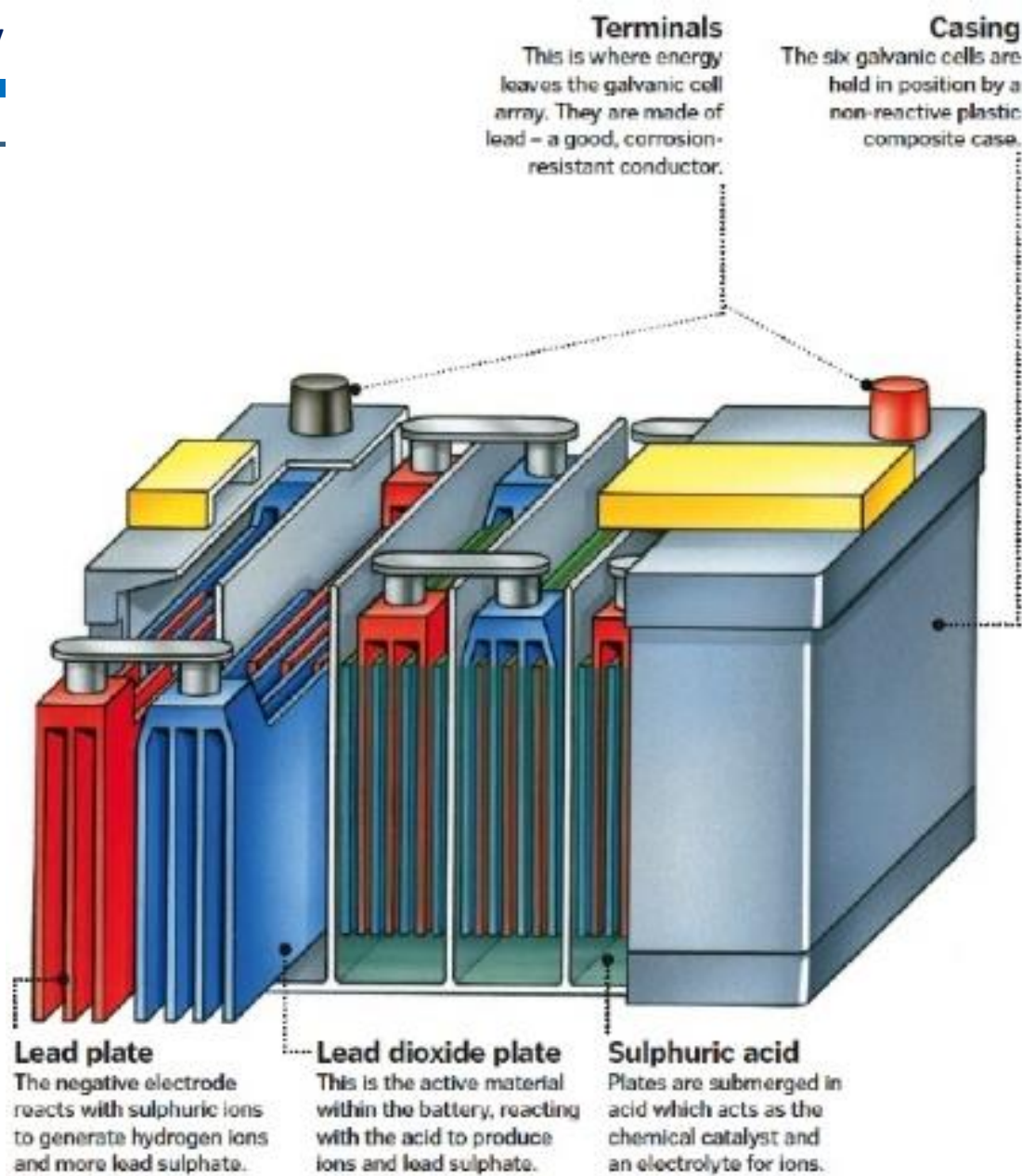

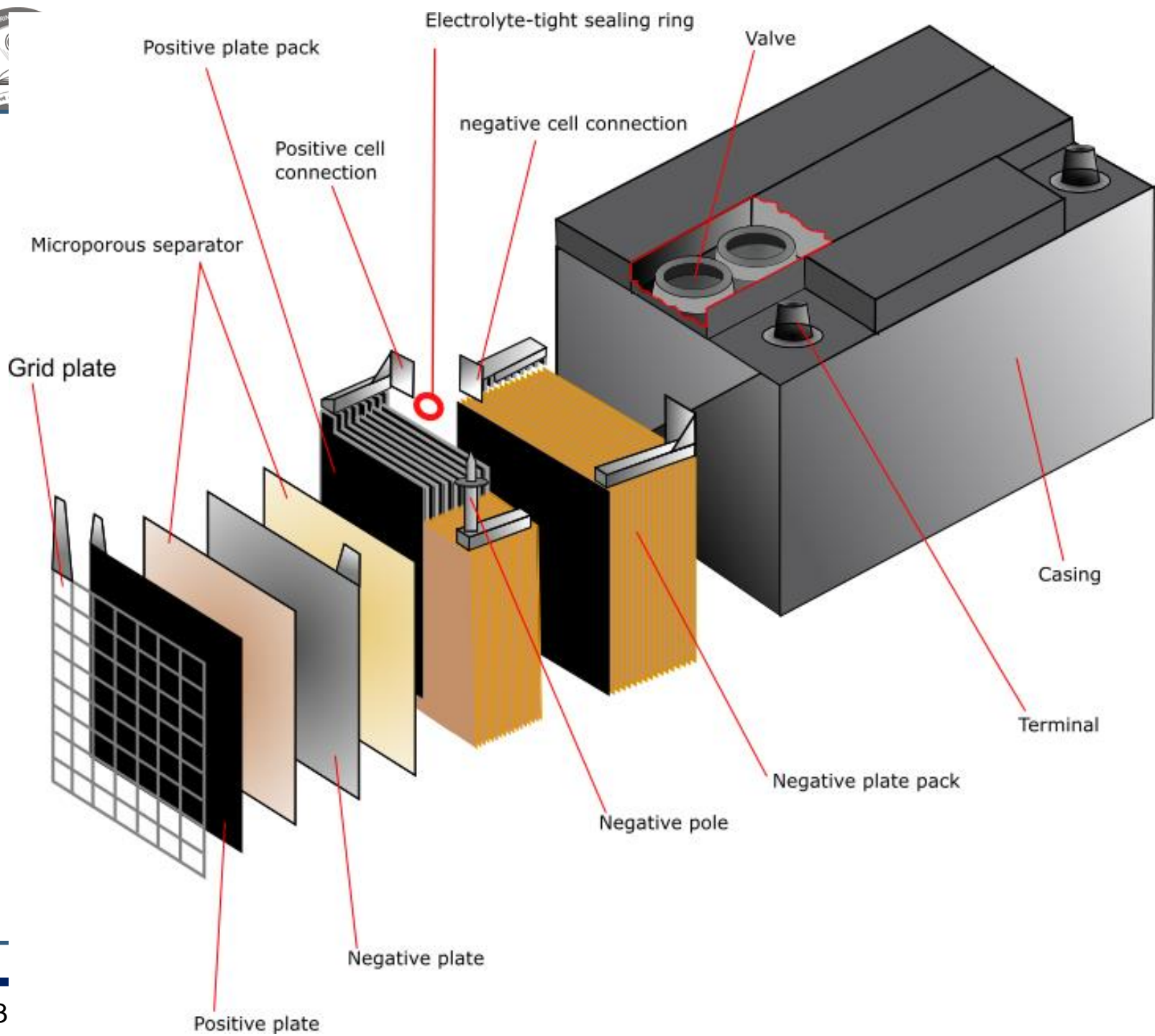



## ❖ Construction:

### 1. Plates:

- Rectangular lattice like grid shape made by **lead-antimony alloy**.
- The active material is held in place by horizontal and vertical bars.
- They further serve to distribute current evenly over the plate.
- Should provide the large surface area to electrolyte
- Should be in close contact with active material for better conductivity.
- Should withstand bumps and vibration

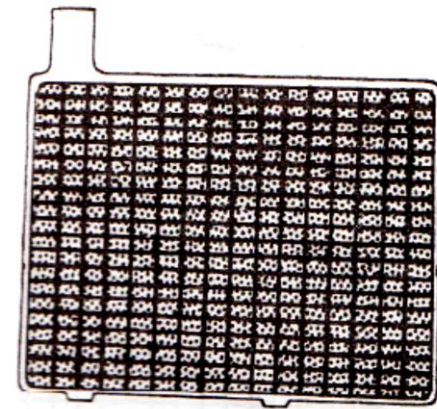
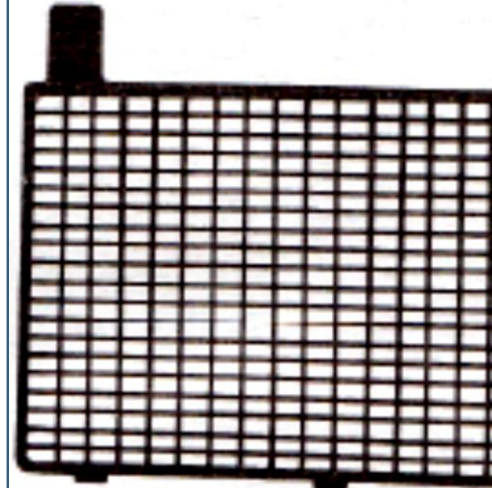

## 2. Separators:

- A small clearance/gap is kept between positive and negative plates.
- In order to prevent the positive and negative plate from actually touching separators are employed in between these plates.
- May be of micro-porous rubber, non-conducting ebonite, glass-mat or micro-porous PVC.
- May be in ribbed shape or simply flat.
- Should have long life
- Should not provide resistance to flow of electrolyte.

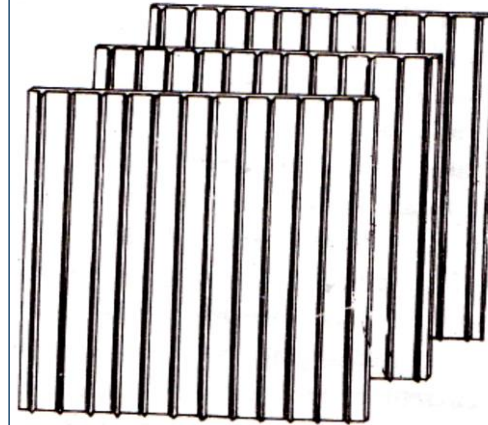



### 3. Group:

- The plates are welded to **lead antimony strap** for forming the battery plate group
- The strap is provided with round terminal post protruding through the cell cover hole.

### 4. Element:

- The battery element consists of two groups of plates- positive and negative assembled together.
- Generally one -ve plate is more than +ve plates.
- For eg. 19 plates element will have 10 -ve and 9 +ve plates.
- Because of more chemical activity at +ve plate area it is essential to have lesser +ve plates.

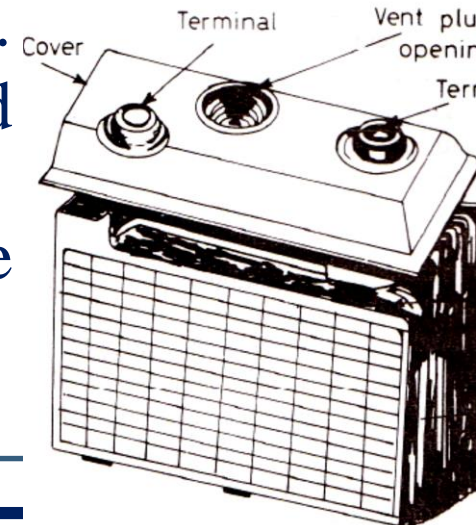
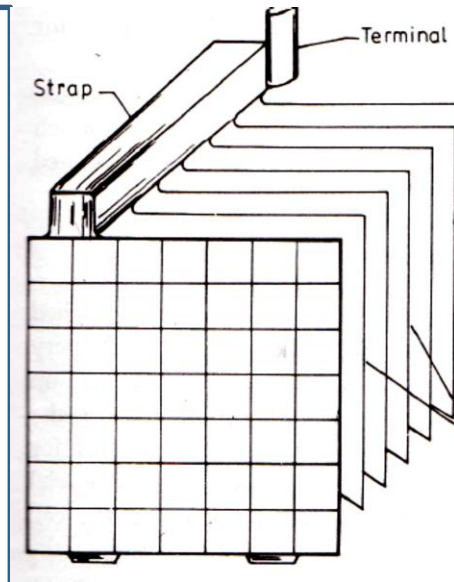

## 5. Container:

- The battery elements are placed in hard rubber, leak proof container with 6 compartments
- The plates rest on ribs formed at bottom of container, the space below and between ribs is meant for storing the sediments formed in normal battery action.
- Short circuiting is also avoided by this arrangement.

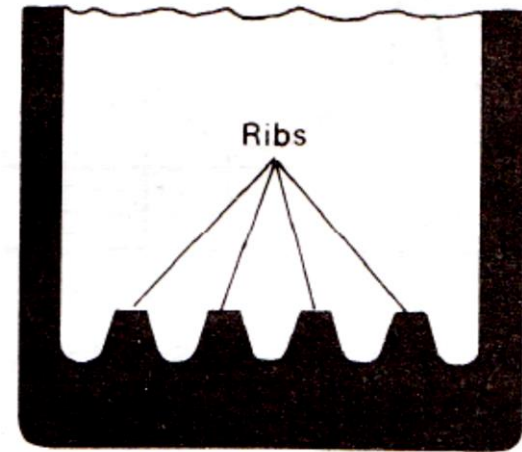

## 6. Cell Connectors:

- The lead bar cell connectors are attached to the cell terminals.
- The individual battery cells are connected in series, thus adding up their voltages.
- Heavy coating of sealing is used to protect them from leakage of current.

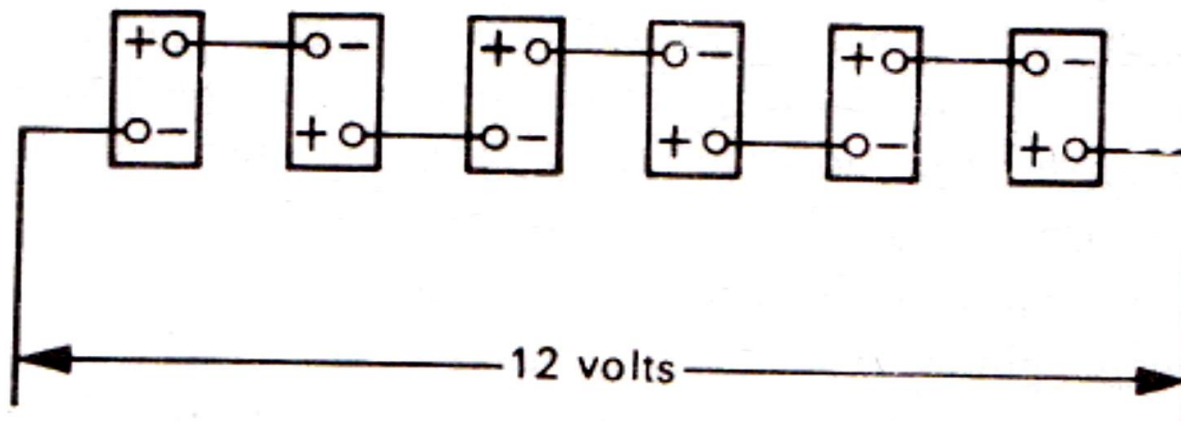

## ❖ Electrolyte:

- Electrolyte is made by diluting sulfuric acid with water.
- The electrolyte used in automobiles battery is of higher density because of two main reason.
  - The volume of electrolyte is limited keeping in view of the size and weight of battery.
  - Automobile batteries are frequently required to give heavy discharge currents due to starting motors.

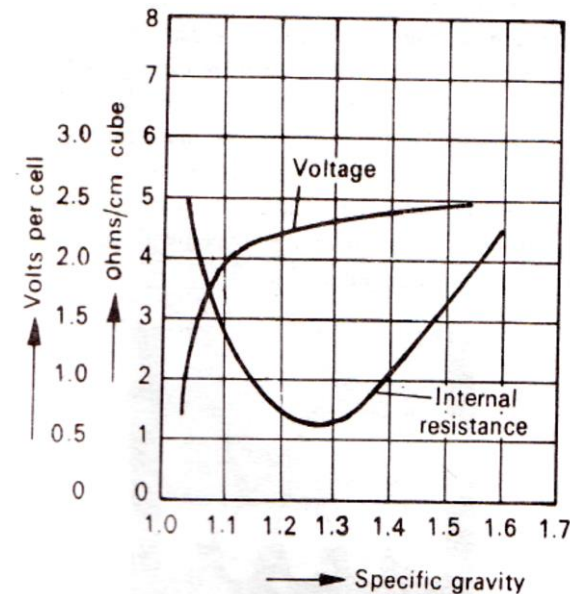



## ***Advantages:***

- Batteries of all shapes and sizes, available in
- Maintenance-free products and mass-produced
- Best value for power and energy per kilowatt-hour
- Have the longest life cycle and a large environmental advantage
- Ninety-seven percent of the lead is recycled and reused in new batteries

## ***Disadvantages:***

- Lead is heavier compared to alternative elements
- Certain efficiencies in current conductors and other advances continue to improve on the power density of a lead-acid battery's design



## ❖ **Battery Ratings:**

- In simple terms, the characteristics or rating of a particular battery are determined by **how much current it can produce and how long it can sustain this current.**
- The rate at which a battery can produce current is determined by the speed of the chemical reaction. This in turn is determined by a number of factors:
  - **Surface area of the plates.**
  - **Temperature.**
  - **Electrolyte strength.**
  - **Current demanded.**
- The actual current supplied therefore determines the overall capacity of a battery. The rating of a battery has to specify the current output and the time.



## ❖ **Ampere hour capacity (20 H Rate)**

- This is now occasionally used but describes how much current the battery is able to supply for either 10 or 20 hours. The 20-hour figure is the most common.
- For example, a battery quoted as being 44Ah (ampere-hour) will be able, if fully charged, to supply 2.2 A for 20 hours before being completely discharged (cell voltage above 1.75 V & temperature 27°C).





## ❖ Reserve capacity (25 A)

- A rating system used now on all new batteries is reserve capacity. This is quoted as a time in minutes for which the battery will supply **25 A at 27° C to a final voltage of 1.75 V per cell.**
- This is used to give an indication of how long the battery could run the car if the charging system was not working.
- Typically, a 44 Ah battery will have a reserve capacity of about 60 minutes.





## ❖ Cold Cranking Rate:

- Batteries are given a rating to indicate performance at high current output and at low temperature.
- A typical value of 170 A means that the battery will supply this current for one minute at a temperature of  $-18^{\circ}\text{C}$ , at which point the cell voltage will fall to 1.4 V (BS – British Standards).
- A 100 Ah battery with 20h rate may be in position to deliver 300 A for a period of 3.6 min at  $-18^{\circ}\text{C}$ .

## ❖ 4h rate:

- Used in case of heavy vehicles like buses and trucks.
- It represents Ah rating of a battery discharged in 4h.
- A battery supplying 25A for 4h will have 100 Ah on 4 hour rate.

## ❖ Battery Performance:

- Fig. shows the changes in the sp. Gravity of electrolyte when the cell is being discharged over the period of 10 hours.
- The graph characteristic depends upon the rate of discharge and permissible final sp. Gravity of electrolyte.
- Sp. Gravity in charged condition is about 1.28 has been discharged over 10h to 1.125.
- A battery should not be discharged fully and then left over for long period because **insoluble lead sulfate** is formed which might cause distortion of plates.

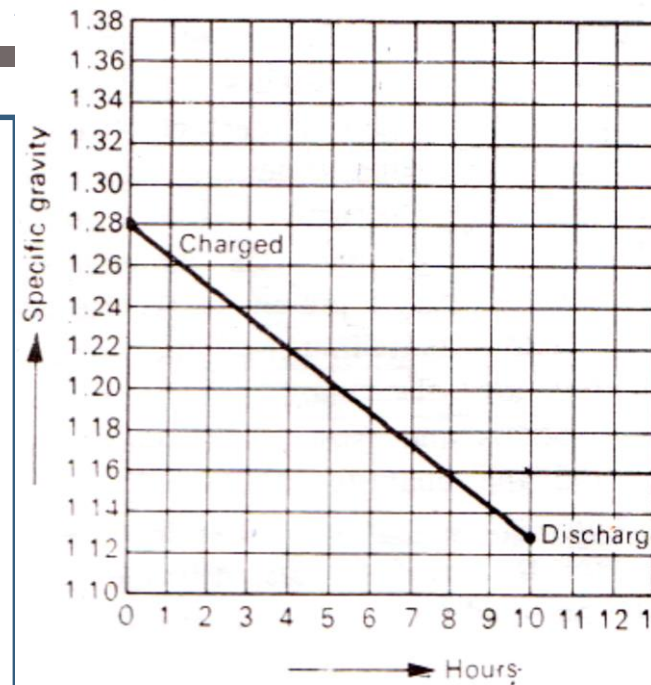

(a)

Sl. No.	Approximate sp. gravity	State of charge of battery
1.	1.260-1.280	Fully charged
2.	1.230-1.260	3/4 charged
3.	1.200-1.230	Half charged
4.	1.170-1.200	1/4 charged
5.	1.140-1.170	About run down
6.	1.110-1.140	Discharged

- From a fig. it can be seen that, when a cell is being charged, its voltage rises continuously for a period of six hours.
- After that there is rapid increase in the cell voltage and it attains the max. voltage of 2.70 V after about 10hrs.
- As the charging current is switched off the cell voltage falls rapidly to about 2.20 V and then finally settles about 2.05 V.

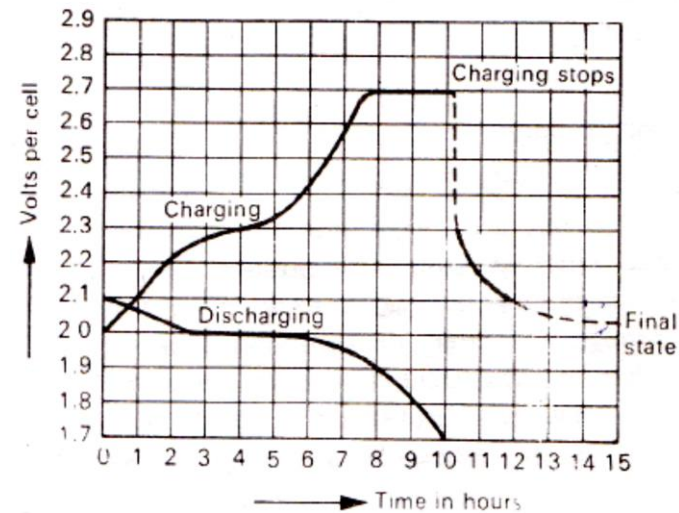

## ❖ Battery Discharge Rate:

- The effect of battery discharge rate on the capacity of the battery and also the terminal voltage per cell at discharge period (for 50 Ah battery based on 20h rating) can be seen from the figure.
- It can be seen that for 10h rating gives 85% of the 20h rating
- In case of 4h rate discharge the battery capacity drops to about 70% of the 20h rating

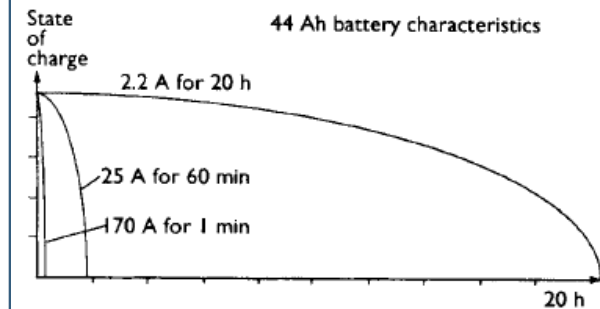
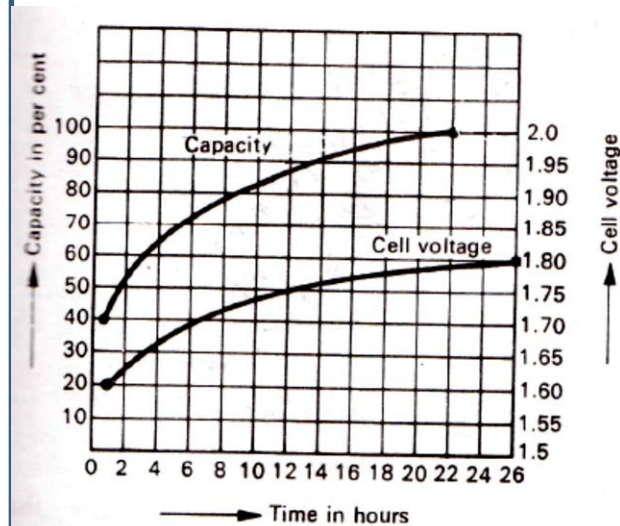

Figure 5.3 Battery discharge characteristics compared



## ❖ **Battery Capacity:**

- In case of cars having 1000 cc engine the batteries used are 40Ah at 20 h rating.
- For 1500-2000 cc engine cars, 43 to 50Ah and cars with engine upto 3000cc use 50 to 70 Ah batteries at 20h ratings.
- American cars having 300 bhp, 400 bhp use 70 to 75 Ah batteries.
- For 200 to less than 300 bhp use 45 to 55 Ah batteries.
- In commercial vehicles, batteries of 90 to 140 Ah at 10h rating in 6v units are used.
- Vehicles having diesel engine use batteries of 300 Ah capacities because these engines need higher current for starting motors.
- Ashok Leyland trucks use two batteries of each 12v or four batteries of 6v each having capacity of 78 to 135 Ah at 20 h rating



## ❖ Battery Efficiency:

- The efficiency of battery is generally defined in terms of Amperes-hours or watt-hours and energy efficiency.
- The battery is far more efficient when discharged at slow rate than when it is discharged rapidly.
- The **lower the temperature the lower the efficiency**. The chemical activity is greatly reduced at lower temperatures and sulfuric acid is not in the position to work so actively on the active materials.

- Battery Efficiency,

$$\text{Ah Efficiency} = \frac{Ah_{discharging}}{Ah_{charging}} \times 100,$$

$$\text{Wh efficiency} = \frac{Wh_{discharging}}{Wh_{charging}} \times 100$$

- At the 20 hour rate this can be as much as 90%.





## Energy Efficiency,

$$\text{Energy efficiency} = \frac{P_d \times t_d}{P_c \times t_c} \times 100\%$$

where  $P_d$  = discharge power,  $t_d$  = discharge time,  
 $P_c$  = charging power,  $t_c$  = charging time.

- A typical result of this calculation is about 75%. This figure is lower than the Ah efficiency as it takes into account the higher voltage required to force the charge into the battery.



## ❖ **Temperature effect on battery characteristics:**

- The battery of the vehicle is less active when cold than at normal air temperature.
- It is because of the fact that the electrical resistance of the electrolyte increases with decrease in temperature.
- The electrolyte gravity also increases and this cannot diffuse effectively into pores of the battery plate material.
- due to both reasons battery capacity falls with decrease in temperature.
- Further during cold weather, the viscosity of the cylinder and bearing lubricating oil increases, with the result that the greater starting torque must be supplied by the cranking motor.
- It has been observed that if the power required to crank an engine at 27° C with oil SAE-20 is denoted by 100% the power required is 155% at 0° C and 250% at -18°C.





## ❖ Self-discharge:

- All batteries suffer from self-discharge, which means that even without an external circuit the state of charge is reduced.
- The rate of discharge is of the order of **0.2–1% of the Ah capacity per day**. This increases with decrease in temperature and the age of the battery.
- It is caused by two factors. First, the chemical process inside the battery changes due to the material of the grids forming short circuit voltaic couples between the antimony and the active material. Using calcium as the mechanical improver for the lead grids reduces this.
- Impurities in the electrolyte, in particular trace metals such as iron, can also add to self-discharge.
- Second, a leakage current across the top of the battery, particularly if it is in a poor state of cleanliness, also contributes to the self-discharge.
- The fumes from the acid together with particles of dirt can form a conducting film. This problem is much reduced with sealed batteries.

## ❖ Battery Tests:

### 1. Hydrometer Test

- For testing the state of charge of a non-sealed type of battery, a hydrometer can be used, as shown in Figure.
- The hydrometer comprises a syringe that draws electrolyte from a cell, and a float that will float at a particular depth in the electrolyte according to its density.
- The density or specific gravity is then read from the graduated scale on the float. A fully charged cell should show 1.280, 1.200 when half charged and 1.130 if discharged.

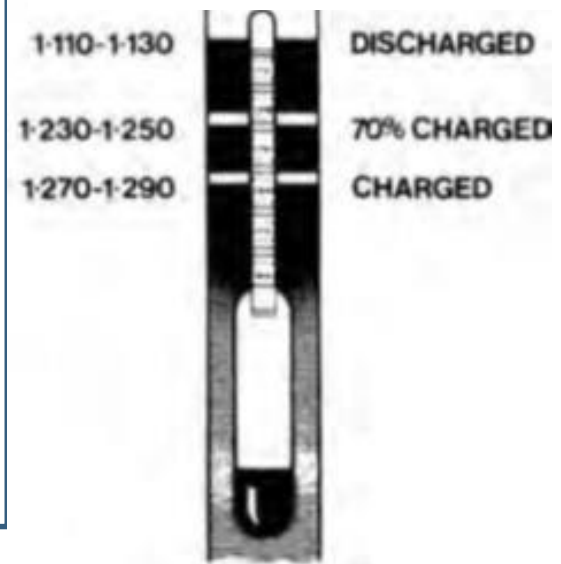
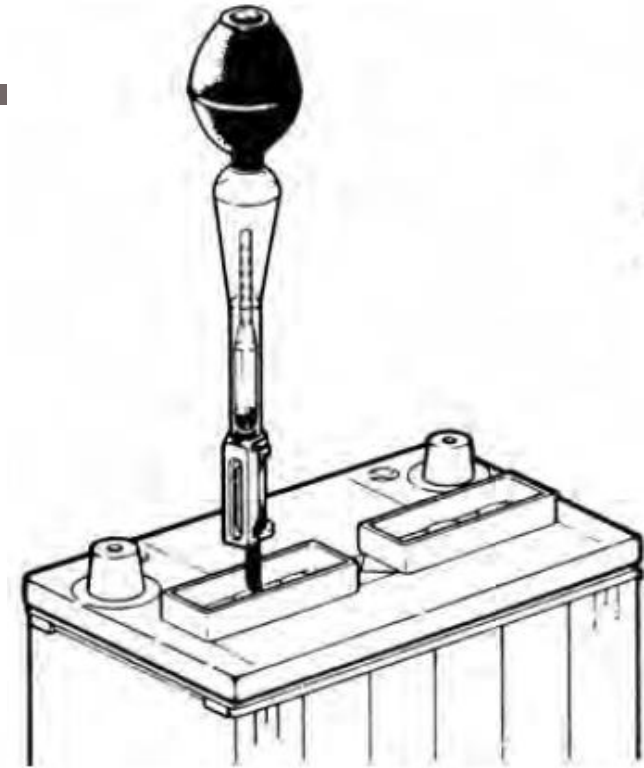

reading at 15°C



Sr. No.	Approx. Sp. Gravity	State of Charge of Battery
1	1.260 – 1.280	Fully charged
2	1.230 – 1.260	$\frac{3}{4}$ th charged
3	1.220 – 1.230	Half charged
4	1.170 – 1.220	$\frac{1}{4}$ th charged
5	1.140 – 1.170	About Run Down
6	1.110 – 1.140	Discharged

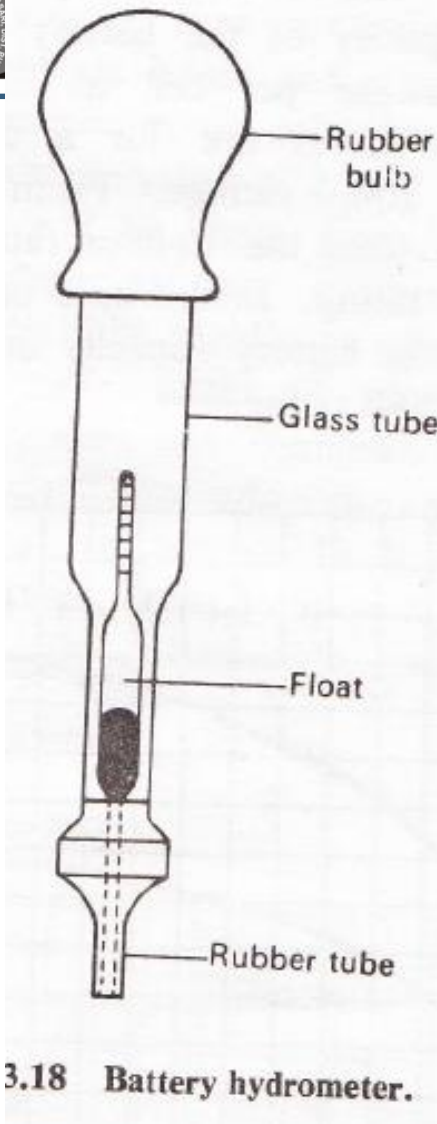

## Hydrometer

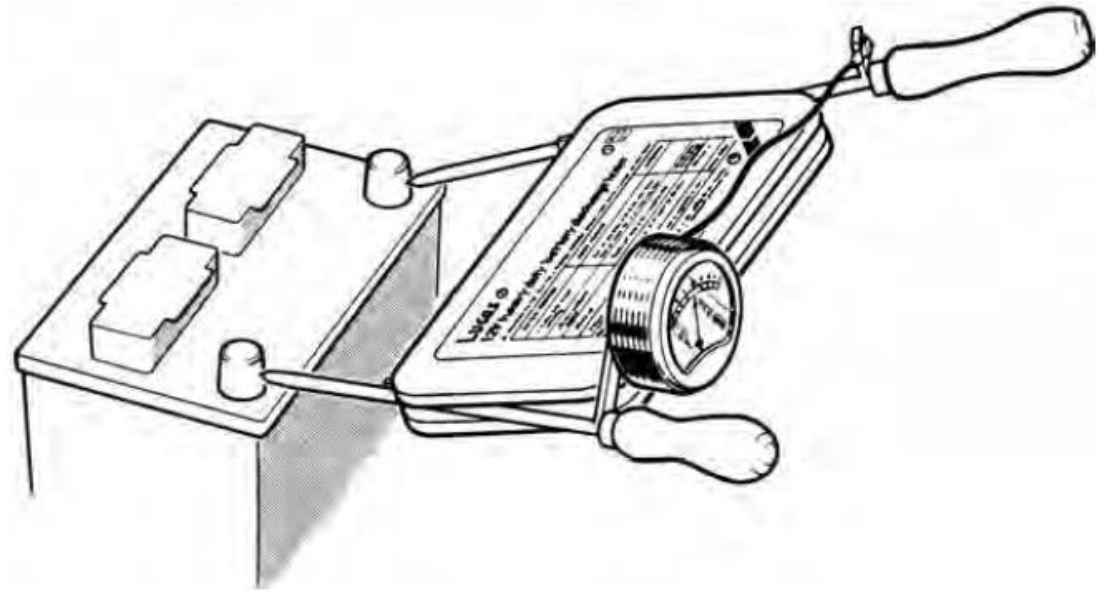

## Heavy Duty Discharge Tester

## 2. Heavy Duty Discharge Tester:

- Most vehicles are now fitted with maintenance free batteries and a hydrometer cannot be used to find the state of charge.
- This can only be determined from the voltage of the battery, as given in Table An accurate voltmeter is required for this test
- A heavy-duty (HD) discharge tester as shown in Figure is an instrument consisting of a low-value resistor and a voltmeter connected to a pair of heavy test prods.
- The test prods are firmly pressed on to the battery terminals. The voltmeter reads the voltage of the battery on heavy discharge of 200–300 A.

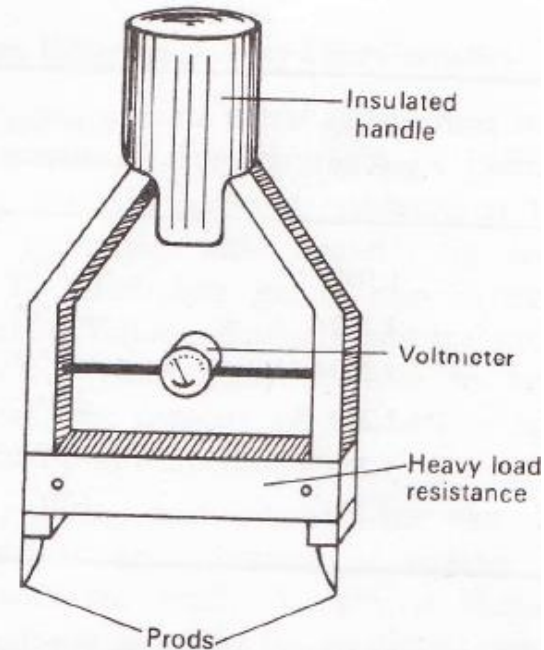





- Assuming a battery to be in a fully charged condition, a serviceable battery should read about 10V for a period of about **10 s**. A sharply falling battery voltage to below 3 V indicates an unserviceable cell.

**Table 5.4** Factors affecting the voltage of a battery

Acid density	Cell voltage	Battery voltage	% charge
1.28	2.12	12.7	100
1.24	2.08	12.5	70
1.20	2.04	12.3	50
1.15	1.99	12.0	20
1.12	1.96	11.8	0

**Table 5.3** State of charge of a battery

Battery volts at 20° C	State of charge
12.0	Discharged (20% or less)
12.3	Half charged (50%)
12.7	Charged (100%)



## ❑ Exide Double Check Tester

### ▪ State of Charge Test:

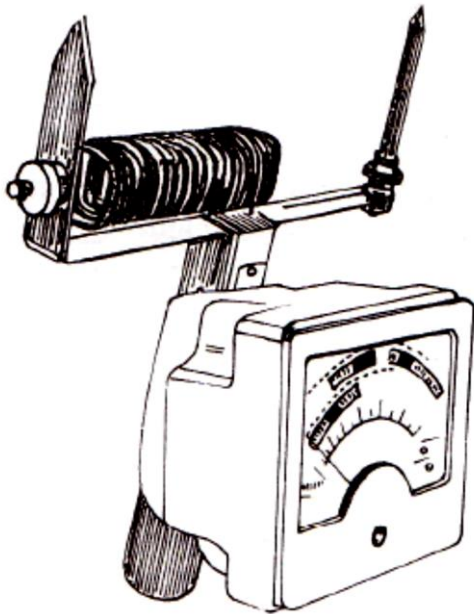

Fig. 3.20 Exide double-check tester (courtesy: Chloride and Exide).

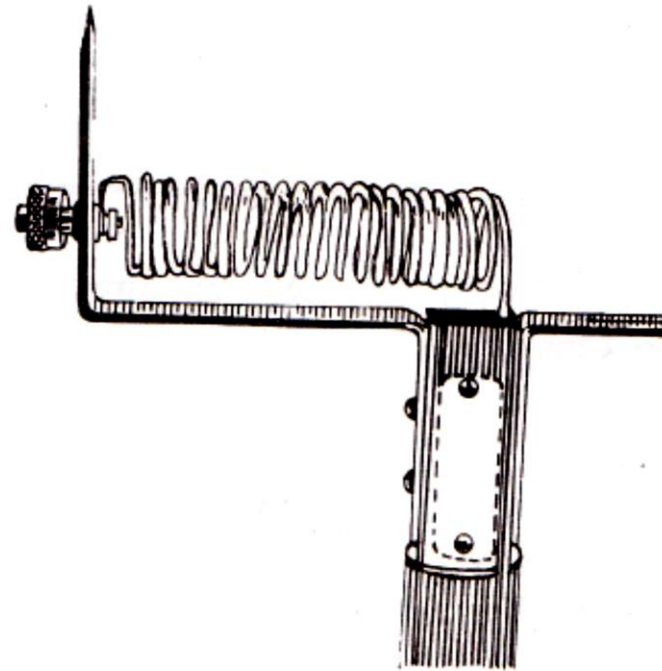
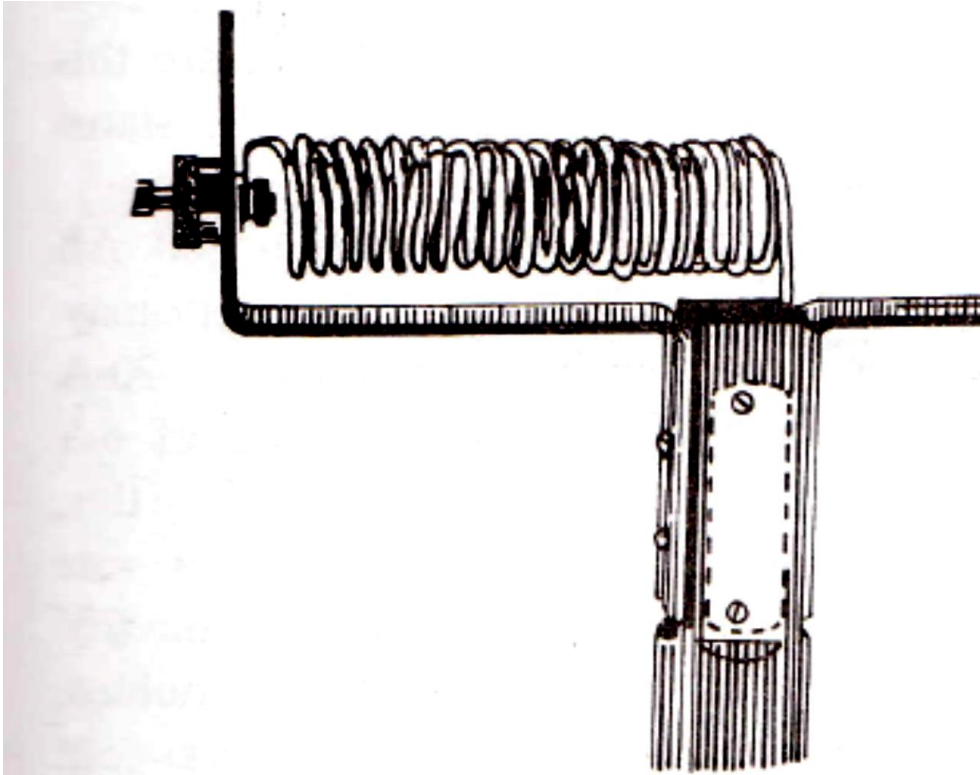

Fig. 3.21 Knurled nut unscrewed (courtesy: Chloride and Exide).



## ■ Battery Discharge Test:



**Fig. 3.22** Knurled nut screwed down on to the surface of flat prod (courtesy: Chloride and Exide).



## ■ **Battery Charge Test:**

- The knurled nut is unscrewed so that the resistor is out of circuit, as shown in figure above. All the lights are switched on for three minutes. (unless the state of charge test has shown the battery in a discharged state).
- Now the lights are switched off and the engine is started. The engine is kept running at moderate speed (i.e at engine speed equivalent of 50Km per hour in top gear).
- The prods are now applied across the cell or to the battery terminals. The meter reading should increase slightly and then remain constant. This constant reading is the true value of charging.
- If the two previous checks indicate a healthy battery, the reading on the charging scale will indicated whether a low, satisfactory or too high charge ins being given.



## Cranking Motor Test:

- Before making this test the electrolyte level in all the cells should be correct, there should be no apparent defects in the battery, and it should be at least half charged.
- Further, the motor should not be operated for more than 30s at a stretch. Before operating it again, it must be allowed to cool, otherwise it may be overheated and get damaged.
- For making the test, earth the ignition primary lead at the distributor, so that the engine does not start. Now operate the cranking motor and check the voltage of each battery cell.
- Generally, if during the test, the cell voltage fall below 1.5V or there is a difference of 0.2V or more between cells, battery trouble may be suspected. Before final conclusion, recharge the battery and check it again.



## Cadmium Test:

- The previously described test are a good indication of battery condition but no satisfactory indication is given as regards the chemical condition of the plates.
- To know the chemical condition of the battery plates, it is necessary to perform cadmium test.
- It consists of finding out the voltage between the negative or positive plate and the cadmium testing strip immersed in the battery electrolyte. A perforated ebonite tube is generally used to enclose the cadmium strip.
- One end of the strip is connected by an insulated conductor to negative terminal of the voltmeter. The other voltmeter terminal is connected to the negative or positive plate, as the case may be.
- The cell voltage is equal to algebraic difference of the cadmium to negative and cadmium to positive voltage readings.



- For conducting the cadmium test, it is essential to have a high grade high resistance voltmeter.
- Further, it should be scaled to give a positive reading of 3V and negative reading of 0.2V. It may even be a 3V center zero instrument. Further, for making this test, the battery should be either on charge or on discharge.
- In a battery in good condition nearing completion of charge at normal rate, the cadmium to positive voltage should be 2.35-2.50V and cadmium to negative voltage -0.1-0.14V, giving a cell voltage of 2.45-2.64 V.
- For a battery discharged at normal rate, its cadmium to negative voltage should not be more than +0.2V and that of cadmium to positive voltage not less than 2.0V, thus giving cell voltage of 1.8V.
- If the cadmium to positive voltage is sufficiently less than 2.0V, the chemical condition of the positive group of plates is not up to the mark. If the cadmium to negative voltage approaches +0.3V, it indicates a poor condition of negative group of plates



**Table 5.2** Common problems with lead-acid batteries and their likely causes

## ❖ Battery Failures:

1. Overcharging Failures
2. Cycling Failure
3. Sulphation Failure
4. Internal Short circuits

Symptom or fault	Likely causes
Low state of charge	Charging system fault Unwanted drain on battery Electrolyte diluted Incorrect battery for application
Low capacity	Low state of charge Corroded terminals Impurities in the electrolyte Sulphated Old age – active material fallen from the plates
Excessive gassing and temperature	Overcharging Positioned too near exhaust component
Short circuit cell	Damaged plates and insulators Build-up of active material in sediment trap
Open circuit cell	Broken connecting strap Excessive sulphation Very low electrolyte
Service life shorter than expected	Excessive temperature Battery has too low a capacity Vibration excessive Contaminated electrolyte Long periods of not being used Overcharging



## ❖ Alkaline Batteries

- Lead-acid batteries traditionally required a considerable amount of servicing to keep them in good condition, although this is not now the case with the advent of sealed and maintenance-free batteries.
- However, when a battery is required to withstand a high rate of charge and discharge on a regular basis, or is left in a state of disuse for long periods, the lead-acid cell is not ideal.
- Alkaline cells on the other hand require minimum maintenance and are far better able to withstand electrical abuse such as heavy discharge and over-charging.





- The disadvantages of alkaline batteries are that they are more bulky, have lower energy efficiency and are more expensive than a lead-acid equivalent.
- When the lifetime of the battery and servicing requirements are considered, the extra initial cost is worth it for some applications.
- Bus and coach companies and some large goods-vehicle operators have used alkaline batteries
- Alkaline batteries used for vehicle applications are generally the nickel-cadmium type, as the other main variety (nickel-iron) is less suited to vehicle use.



- The main components of the nickel-cadmium – or Nicad – cell for vehicle use are as follows:
  - **positive plate – Nickel hydrate (NiOOH);**
  - **negative plate – Cadmium (Cd);**
  - **electrolyte – potassium hydroxide (KOH) and water (H<sub>2</sub>O).**
- The process of charging involves the oxygen moving from the negative plate to the positive plate, and the reverse when discharging.
- When fully charged, the negative plate becomes pure cadmium and the positive plate becomes nickel hydrate.
- A chemical equation to represent this reaction is given next but note that this is simplifying a more complex reaction.

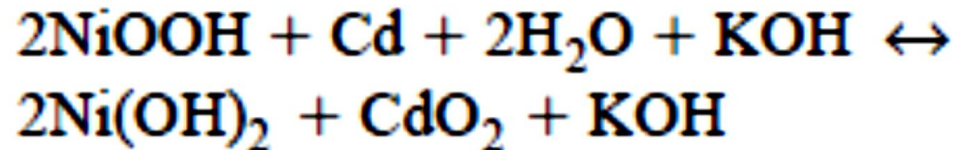

- The 2H<sub>2</sub>O is actually given off as hydrogen (H) and oxygen (O<sub>2</sub>) as gassing takes place all the time during charge.
- It is this use of water by the cells that indicates they are operating, as will have been noted from the equation. The electrolyte does not change during the reaction.
- This means that a relative density reading will not indicate the state of charge. These batteries do not suffer from over-charging because once the cadmium oxide has changed to cadmium, no further reaction can take place.



- The cell voltage of a fully charged cell is 1.4V but this falls rapidly to 1.3 V as soon as discharge starts.
- The cell is discharged at a cell voltage of 1.1V. Figure 5.10 shows a simplified representation of a Nicad battery cell.
- Ni-MH or nickel-metal-hydride batteries show some promise for electric vehicle use.

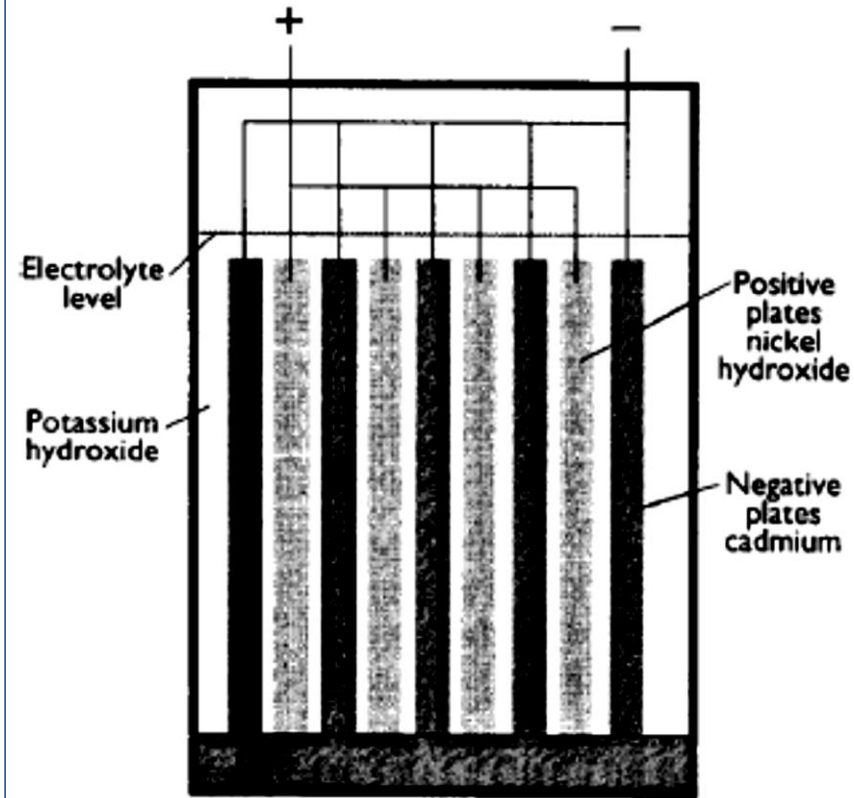

Figure 5.10 Simplified representation of a Nicad alkaline battery cell



## **Major Disadvantages of Lead Acid Battery:**

1. It is relatively heavy for given capacity.
2. It is liable to sulphate if left in fully or partly discharged condition.
3. It will start self discharging if allowed to stand for long periods.
4. It is sensitive to shock and vibrations.
5. It is liable to damage if overcharged.
6. It is liable to damaged if discharged above certain current rate and
7. It is unsuitable for use at lower temperatures due to its danger of freezing more at low acid gravities.



## Advantages of Alkaline Battery:

1. It has a much longer life namely 2.5 to 4 times that of lead acid battery.
2. Its maintenance and labor cost is minimal and this compensates to some extent the higher initial cost.
3. It is **lighter in weight than the lead-acid battery** of equal capacity.
4. It has ability to withstand low atmospheric temperatures without damage.
5. Mechanically much stronger than the lead acid battery and can stand severe shocks and vibrations without detrimental effects on the plates and casing.
6. It has ability to withstand overcharging or rapid discharging.
7. It has extremely low self-discharge.
8. It can be left discharged for long periods without damage



## ❖ Maintenance-free batteries

- In addition to the traditional, ‘wet’ batteries and in response to market demand for batteries that no longer require to be topped up, maintenance-free batteries have been introduced.
- These batteries are called as fully **maintenance-free batteries**. They are also called **VRLA**, or “**Valve Regulated Lead Acid**” batteries.
- Maintenance-free batteries should **never be topped up**, therefore there are no filler caps on top. The filler cap is replaced by an over-pressure valve that is normally closed.
- Any gas that forms ends up being recombined in the cell as water. This way there is always sufficient electrolyte in the battery.





- Good quality maintenance-free batteries have the advantage of being **guaranteed for life!** Naturally the user never forgets to carry out maintenance.
- Maintenance-free batteries have to be charged up with a **charger that is suitable for this type of battery.**
- There are two primary types of VRLA batteries, **absorbent glass mat (AGM)** and **gel cell**. Gel cells add silica dust to the electrolyte, forming a thick putty like gel.
- AGM (absorbent glass mat) batteries feature fiberglass mesh between the battery plates which serves to contain the electrolyte and separate the plates.
- Both types of VRLA batteries offer advantages and disadvantages compared to flooded **vented lead–acid (VLA)** batteries, as well as to each other



- Lead–acid cells consist of two plates of lead, which serve as electrodes, suspended in an electrolyte consisting of diluted sulphuric acid.
- VRLA cells have the same chemistry. In AGM and gel type VRLA's, the **electrolyte is immobilized**.
- In AGM this is accomplished with a fiberglass mat; in gel batteries or "gel cells", the electrolyte is in the form of a paste like gel created by adding silica and other gelling agents to the electrolyte.

## SEALED VRLA BATTERY CONSTRUCTION

### PATENTED SEALED POST

prevents acid seepage, reduces corrosion – extends battery life.

### HEAT SEALED CASE TO COVER

protects against seepage and corrosion – bonded unit gives extra strength.

### POLYPROPYLENE COVER AND CONTAINER

assures reserve electrolyte capacity for cooler operating temperatures; gives greater resistance to gas and oil – and impact in extreme conditions!

### SAFETY VALVE/ FLAME ARRESTOR

relieves excess pressure.

### THRU-PARTITION CONSTRUCTION

provides shorter current path with less resistance than “over the partition” construction – you get more cranking power when you need it!

### SPECIAL ACTIVE MATERIAL

is compounded to withstand vibration, prolong battery life and dependability.

### SPECIAL GRID DESIGN

withstands severe vibration, assures maximum conductivity.

### SPECIAL SEPARATOR

makes the battery spill-proof. Valve regulated design eliminates water loss and the need to refill with acid.

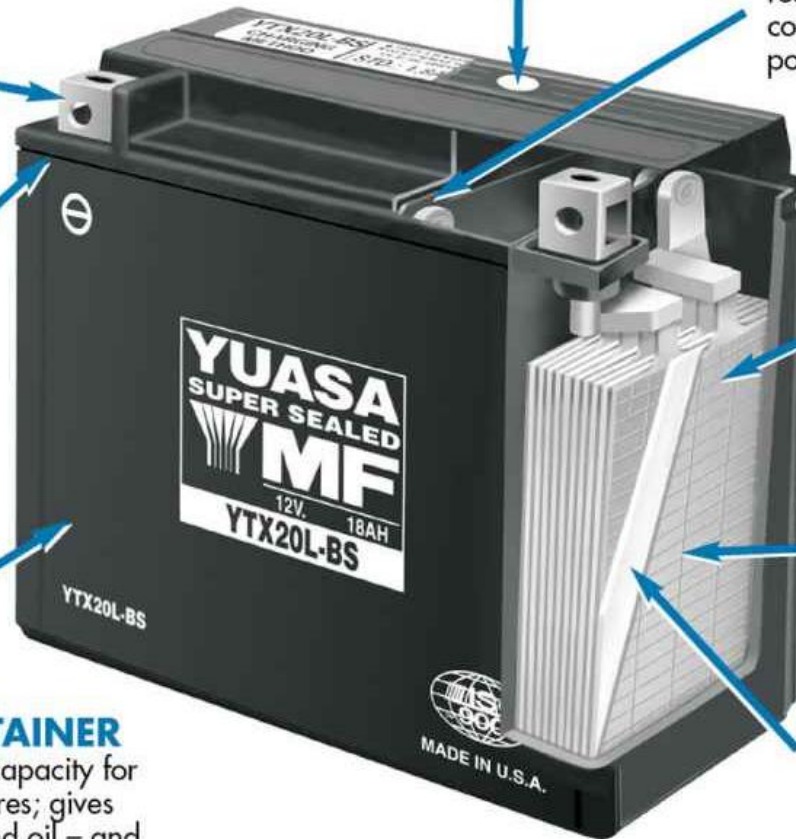



Lead plate

Absorbed glass mat

Case

Terminal



- **AGM batteries** use separators consisting of a sponge-like glass fibre mat that is squeezed between the flat battery plates. The electrolyte is incorporated in the glass fibre mat. The first AGM batteries were developed during the 1980's in Japan and were used mainly in the UPS market. In the meantime development has continued and there are now AGM batteries for the cyclical battery market.
- **GEL batteries** use traditional separators, except that a silicate is added to the acid whereby the acid becomes a gel after initial filling. Gel batteries have been in existence since the 1950's and have in the meantime created a good reputation for maintenance-free batteries.





- When a cell discharges, the lead and diluted acid undergo a chemical reaction that produces lead sulphate and water. When a cell is subsequently charged, the lead sulphate and water are turned back into lead and acid.
- In all lead–acid battery designs, charging current must be adjusted to match the ability of the battery to absorb the energy.
- If the charging current is too great, electrolysis will occur, decomposing water into hydrogen and oxygen, in addition to the intended conversion of lead sulphate and water into lead dioxide, lead, and sulphuric acid (the reverse of the discharge process).
- If these gases are allowed to escape, as in a conventional flooded cell, the battery will need to have water (or electrolyte) added from time to time.



- In contrast, VRLA batteries retain generated gases within the battery as long as the pressure remains within safe levels.
- Under normal operating conditions the gases can then recombine within the battery itself, sometimes with the help of a catalyst, and no additional electrolyte is needed.
- However, if the pressure exceeds safety limits, safety valves open to allow the excess gases to escape, and in doing so regulate the pressure back to safe levels (hence "valve regulated" in "VRLA").





## ❑ **Nickel Based Batteries:**

- Nickel based batteries were first invented over 100 years ago when the only alternative was lead acid and are so called because of their use of nickel metals in the electrodes.
- In the 20th century they established a name for themselves as tough, robust and functional – powering everything from small hand held devices to aircraft starter motors.
- Nickel batteries stand out for their long operating life and were used at the start of the twentieth century to power cars when many thought electric vehicles would become the norm and gasoline was a passing fad.



- In more recent years this chemistry has lost out to Lithium based batteries that offer more efficiency and greater power at a similar or lower cost. They have, however, not been completely replaced as they are still far more stable, perceived by many as tougher, have a longer operating life and can handle higher temperature extremes.
- Rechargeable alkaline batteries employ a nickel hydroxide based cathode, with either a metallic anode (Nickel-Cadmium (Ni/Cd), Nickel-Iron (Ni/Fe), Nickel-Zinc (Ni/Zn) or a hydrogen storing anode (Nickel/H<sub>2</sub>, Nickel-Metal Hydride (Ni/MeH)).



- Due to technical limitations on maintenance and long-term cycling performance, Ni/Fe and Ni/Zn batteries cannot be used for automotive or stationary applications.
- Ni/MeH is technically superior to Ni/Cd in a number of aspects and can be used in many applications.
- Both Nickel/Hydrogen (Ni/H) and Ni/MeH batteries are, in principle, the same battery system, utilising nickel hydroxide (NiOOH) as positive and hydrogen (H<sub>2</sub>) as negative electrode materials.
- In Ni/MeH batteries a hydrogen storage alloy is used. Both systems have an excellent cycle life.



## ❑ Basic structure of a Nickel battery

- The core of a Nickel battery is made up of:
  - A negative electrode.
  - A positive electrode.
  - A separator to ensure the plates do not touch but porous enough to allow chemical reactions between the two via an electrolyte solution which is usually impregnated into the separator material.
- These three elements are wound into a cylindrical shape often referred to as the **jelly roll** or **swiss roll** structure.

Basic Structure of a Nickel Cell Battery

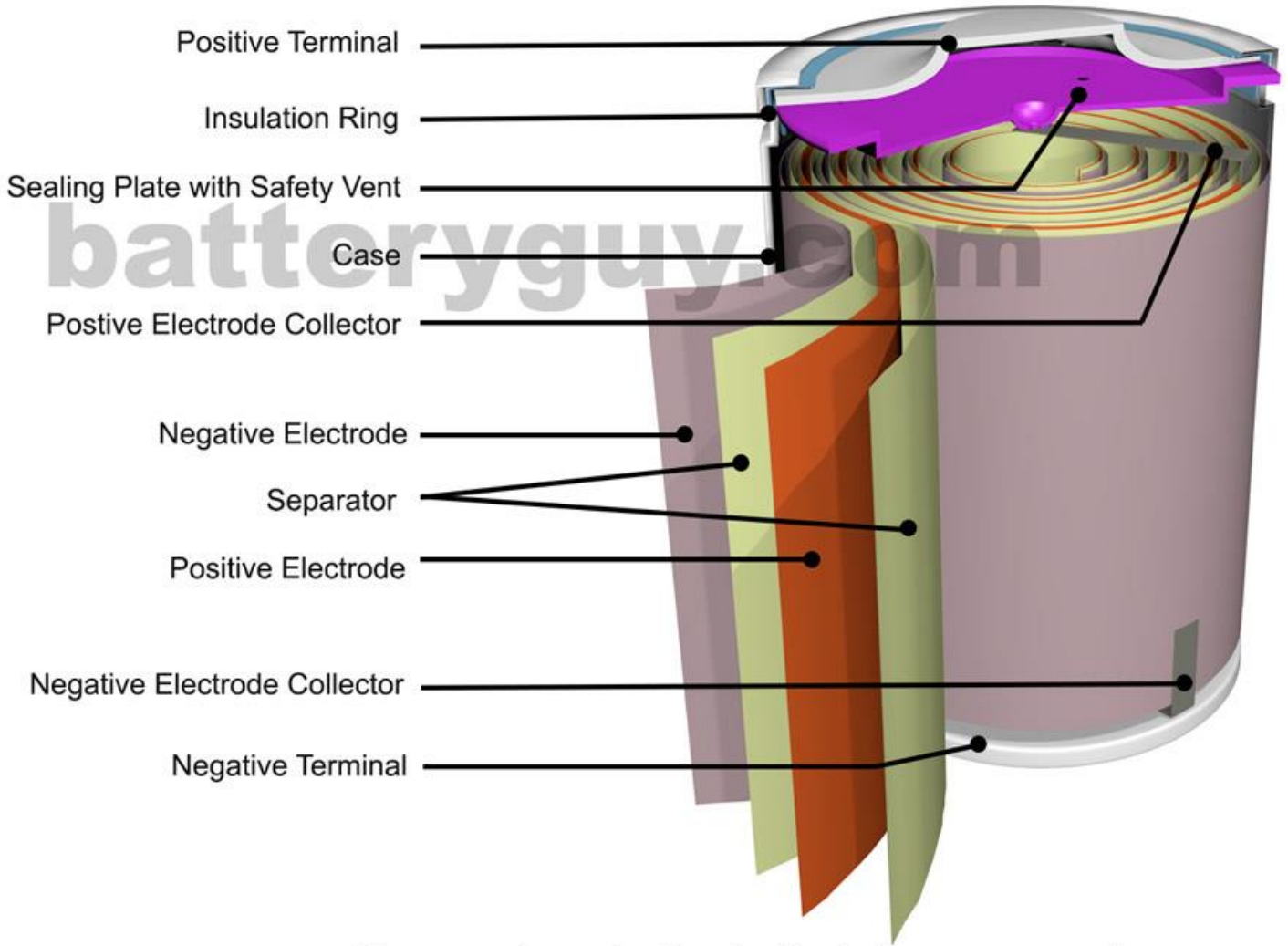

*Sizes, spacing and colors for illustration purposes only.*

[https://youtu.be/fRVZYUXcE\\_s](https://youtu.be/fRVZYUXcE_s)

Source- batteryguy.com



- At the bottom of the battery a metal tab connects the **negative electrode** to the **negative terminal**, hence the name **negative electrode collector**.
- The **negative terminal** is usually in direct contact with the **case** of the battery so an **insulation ring** at the top ensures the **positive terminal** is isolated from the case.
- Also at the top of the battery is another metal tab (known as the **positive electrode connector**) which connects the **positive electrode** to a **sealing plate**.
- This is in direct contact with the **positive terminal** and seals in the corrosive **electrolyte** but features a **self sealing vent** which allows gases to escape if the battery malfunctions or is abused through activities such as over or incorrect charging.

## ❑ Nickel battery sizes

■ The most common commercially available nickel based battery sizes are:

- D cells
- C cells
- AA cells
- AAA cells
- Sub-C (also known as SC) cells
- 9 Volt
- Button

### The BatteryGuy.com Knowledge Base

Common nickel battery sizes (other sizes exist)

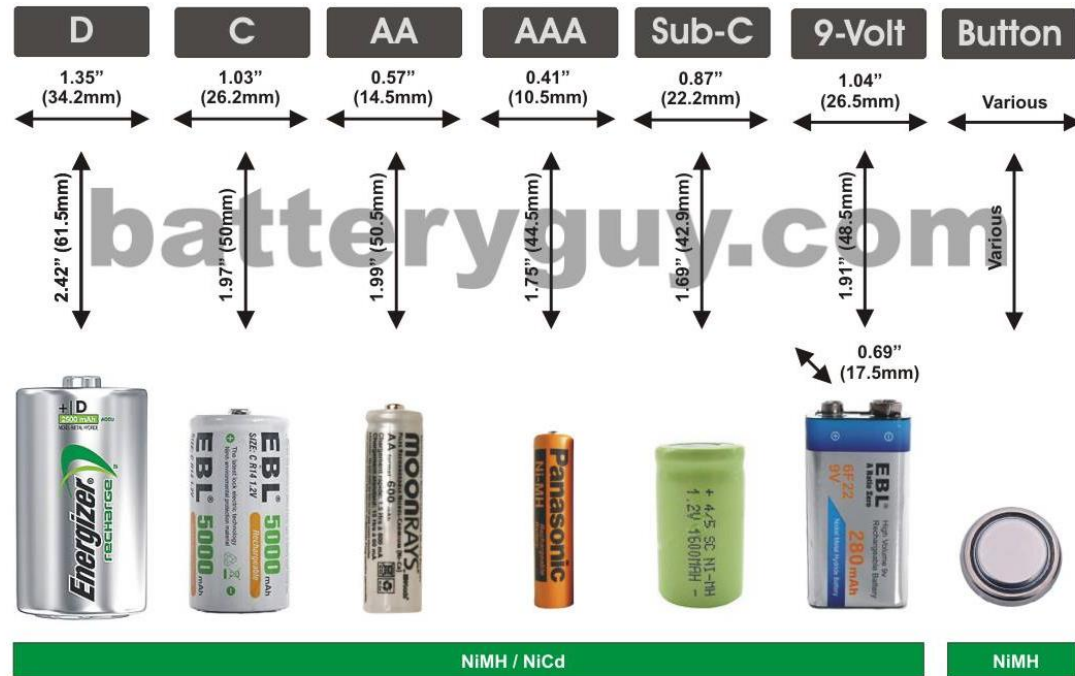





## ❑ Nickel battery types

- Nickel based batteries come in a variety of chemistries:
  - Nickel Iron (NiFe)
  - Nickel Zinc (NiZn)
  - Nickel Cadmium (NiCd)
  - Nickel Metal Hydride
- These different chemistries have been developed over the last century but newer technology does not always mean the battery type is ‘better’ in every aspect. All the chemistries developed to date are still in use in various industries or commercially.



## ❑ **Nickel Iron (NiFe)**

- The first commercially available nickel based battery was Nickel Iron. Patented by Thomas Edison in 1902 it lasts up to four times longer than lead acid and was the battery of choice for electric vehicles at the turn of the century. Although generally seen as having an operating life of 50 years some electric cars produced before the First World War still have their original battery!
- **Advantages**
  - **Good at handling overcharge and discharge**
  - **Vibration resistant** – often used in the mining industry as well as metro systems such as the London Underground and New York Subway
  - **Long operating life** – some units over 100 years old are still operational
- **Disadvantages**
  - **Low specific energy (50 Wh/kg)** – one of the worst ratios in the battery world alongside lead acid
  - **Poor performance at low temperatures**



## ❑ Nickel Zinc (NiZn)

- As gasoline power took over the automotive industry and lead acid was adopted as the battery of choice for engine starting (due to its lower price) nickel based batteries fell into relative obscurity with the exception of some industrial applications such as mining and railroads where they handled vibration better than other alternatives.
- However Thomas Edison was not done with Nickel and had patented the Nickel Zinc battery in 1901. With a 1.65 cell voltage and specific energy of 100Wh/kg it offered more power with greater efficiency over a wide temperature range but was let down by a **short cycle life and high self-discharge rate**.
- Advances have been made to address these short comings and some AA consumer units are in production today that use this chemistry but they are rare compared to other nickel based versions.



## Nickel Cadmium (NiCd)

- The real break through came in the mid 20th century when technological advances lead to the introduction of Nickel Cadmium batteries.
- It was small enough to power hand held devices such as radios and the first widely available rechargeable cell in a world that had been dominated by disposable zinc cobalt batteries.
- Larger versions also became popular in applications such as aircraft starter motors due to their safe stability and tough nature.
- However the highly toxic cadmium used by the battery is known to leak from discarded batteries, especially in land fills, and this environmental hazard remained a cloud over an otherwise effective and popular unit.



## ■ Advantages

- **High cycle life** – up to 2,000 discharge/recharge cycles
- **Vibration resistant** – popular with applications such as power tools
- **Long operating life** – up to 20 years
- **Low temperature friendly** – can operate at -40F(-40C)
- **Low cost** – comparable with Nickel Metal Hydride and slightly more expensive than Lithium.
- **Good at handling power surges** – for such applications as flash photography.
- **Easy to ship and transport** – compared to lithium.

## ■ Disadvantages

- **Low specific energy (up to 80 Wh/kg)** – compared to the more recent Nickel Metal Hydride and Lithium based alternatives.
- **Contains toxic material** – distribution and disposal are heavily regulated in many countries
- **High self discharge (10% per month)** – compared to Lithium, Alkaline and Lead Acid
- **Memory effect myth causes concern** – more a perception than a reality



## ❑ **Memory Effect in Ni-Cad Batteries:**

- There are a few hot potatoes in the battery world and memory effect in NiCad Cadmium batteries is one of them.
- The story goes that if you discharge a Nickel Cadmium battery to exactly the same point **thousands of times and then recharge it, the battery will remember this discharged point.**
- As a result, if you then discharge the battery to the moment when it expects recharging to start, but instead of recharging you continue to discharge, the voltage will suddenly drop. Further reading- [memory effect myth](#)





## ❑ Nickel Metal Hydride (NiMH)

- In the 1980s nickel technology was improved with the introduction of Nickel metal hydride batteries which offered better specific energy (Wh/kg) and a greater cycle life although it is not as tough and has a higher self-discharge rate.
- Its main advantage however was the removal of toxic content and, by offering a new chemistry, it was also able to shake off the memory effect myth.



## ❑ Advantages

- **Recyclable** – expensive nickel content makes this viable
- **High specific energy** – up to 140 Wh/kg as of advances made as recently as 2015, only some Lithium-Ion types perform better.
- **Low cost** – initially more expensive than Nickel Cadmium it is now broadly similar
- **Easy to transport** – compared to Lithium
- **High cycle life** – up to 3,000 cycles
- **Operating life** – comparable to Lithium but shorter than Alkaline
- **No memory effect myth**



## ❑ Disadvantages

- **High self discharge** – 20% in the first 24 hours and 10% per month thereafter
- **Requires a specialist charger**
- **Voltage** – at 1.2 volts per cell it packs less power than Alkaline or Lithium alternatives.



## Nickel hydrogen

- This chemistry is only used in very specialist applications due to the high cost of production and low specific energy (up to 70 Wh/Kg).
- Nickel hydrogen is often used in satellites as it can handle temperature extremes and full discharges while offering a long service life.

## Nickel Zinc button batteries

- Although not hugely popular there are non-rechargeable (primary) nickel based button batteries available and many are manufactured by well known brands such as Varta.
- Offering a voltage of 1.65 volts they are more power than the 1.55 volts of silver oxide and often found in watches, medical devices, calculators, remote controls, laser pointers, photographic equipment, etc.



## ❑ **Nickel versus Alkaline**

### ■ **Advantages**

- Wider operating temperature range
- Much longer cycle life
- Much longer operating life

### ■ **Disadvantages**

- Lower specific energy (Wh/kg)
  - Lower cell voltage
  - Higher self-discharge
- The higher cell voltage of alkaline still makes it more attractive in applications where power is needed fast, such as rapid photography shooting using a flash, but here lithium has proved far superior with most types offering cell voltages of 3.
- Thus Alkalines are generally consigned to uses where it is still a leader – low self discharge and a long operating life. This makes it ideal for standby applications such as smoke alarms or in remote controls.



## **Nickel versus Lithium**

### ■ **Advantages**

- Stability
- Wider operating temperature range

### ■ **Disadvantages**

- Higher self-discharge
  - Lower specific energy (Wh/kg)
  - Lower cell voltage
- Nickel's position as a 'better' option to lithium has gradually been eroded over time as lithium's production costs have fallen and technological advances have improved its cycle life.
- However nickel based batteries are still seen by many as tougher and safer.





## ❑ **Lithium Based Batteries:**

- Lithium batteries are so called because the metal they originally used as plates is lithium based as apposed to, for example, lead in lead acid batteries.
- For disposable lithium batteries this is still true and hence they are known as **lithium metal batteries**.
- In the rechargeable version these plates have actually been replaced over time with non-lithium metals but the chemical process still relies on lithium ions and hence they are referred to as **lithium-ion batteries**.



- Before their invention nickel based batteries served the market for rechargeable units while alkaline were most popular for those needing a disposable option.
- **Lithium offers numerous advantages:**
  - Higher specific energy – better Watt hours per kilogram (Wh/kg) ratings.
  - Much higher cell voltage.
  - Stable voltage during discharge.
  - Better shelf life.
  - Lower self-discharge (versus Nickel).
  - Flexibility in shapes that can be manufactured.
  - Literal flexibility with cells that can bend.



## ■ However lithium still has some limitations

- Safety issues make shipping and transportation complex and restrict where they can be used.
- Some other chemistries perform better at temperature extremes.
- Nickel based batteries still offer a better cycle life.
- Lead acid batteries remain better at high current applications such as engine starting and powering larger appliances.
- Production costs remain higher than some chemistries like Zinc-Carbon.

Further Reading- [Safety issues of lithium batteries](#)



## ❑ Types of lithium batteries

**1. Lithium Metal** – primary/disposable

**2. Lithium-ion** – secondary/rechargeable

- **Lithium-ion Cobalt Oxide** – found in most mobile devices and many cameras due to their high specific energy of up to 200Wh/kg.
- **Lithium-ion Manganese** – more stable than Cobalt Oxide and better at delivering high current this is popular in electric vehicles and power tools although it has a shorter calendar life and cycle life.
- **Lithium-ion Iron Phosphate** – the safest Lithium-ion battery with a long cycle life and the ability to deliver high current it is ideal for hybrid and stop/start cars but has a very short calendar life.



- **Lithium-ion Nickel Cobalt Aluminum Oxide** – the best specific energy in this chemistry but costly and with a short cycle life it is only used in some specialist industrial applications.
- **Lithium-ion Titanate** – operates at very low temperatures but is costly to produce and has low specific energy so it is only found in some specialist applications.
- **Lithium-Ion Nickel Manganese Cobalt Oxide** – long lasting and excellent at producing high power makes this variant popular in power tools and smaller electric vehicles but does not have a good specific energy.



- **Lithium Polymer** – secondary/rechargeable – seen as a safer alternative to lithium-ion that can be manufactured even thinner and weigh less but at a higher cost.
- **Lithium Sulfur (Li-S)** – secondary/rechargeable – a possible replacement to lithium-ion in the future with a cycle life of up to 1,500 and specific energy of up to 500 Wh/Kg but the technology has yet to be commercialized.
- **Lithium Air (Li-Air)** – secondary/rechargeable – currently more theory than reality but with the possibility to offer a specific energy of over 11,000 Wh/Kg (the same as gasoline and way beyond the 260 Wh/Kg of the best available lithium-ion options). Research is ongoing.
- **Lithium Silicon** – secondary/rechargeable – also still on the drawing board but attracting research as it could offer specific energy of over 4,000 Wh/Kg which is 15 times better than the best lithium-ion batteries





## ❑ Basic Structure of Lithium Cell Batteries

- A lithium battery is made up of an **Anode (Negative)** and a **Cathode (Positive)** immersed in **electrolyte**. When connected to an outside device, chemical reactions take place between the plates.
- These plates cannot touch or they would immediately short out the battery, so a porous **separator** is placed between them allowing the electrolyte to move, while keeping the plates separate.
- **Terminal plates** are placed at the top and bottom of the battery with terminal leads acting as connectors to the Cathode (Positive Terminal) and Anode (Negative Terminal)
- The line of connections can also be thought of this way:
  - Cathode (Positive Electrode) *connects to* Positive Terminal Lead *connects to* Positive Terminal.
  - Anode (Negative Electrode) *connects to* Negative Terminal Lead *connects to* Negative Terminal.



Basic Structure of a Lithium Cell Battery

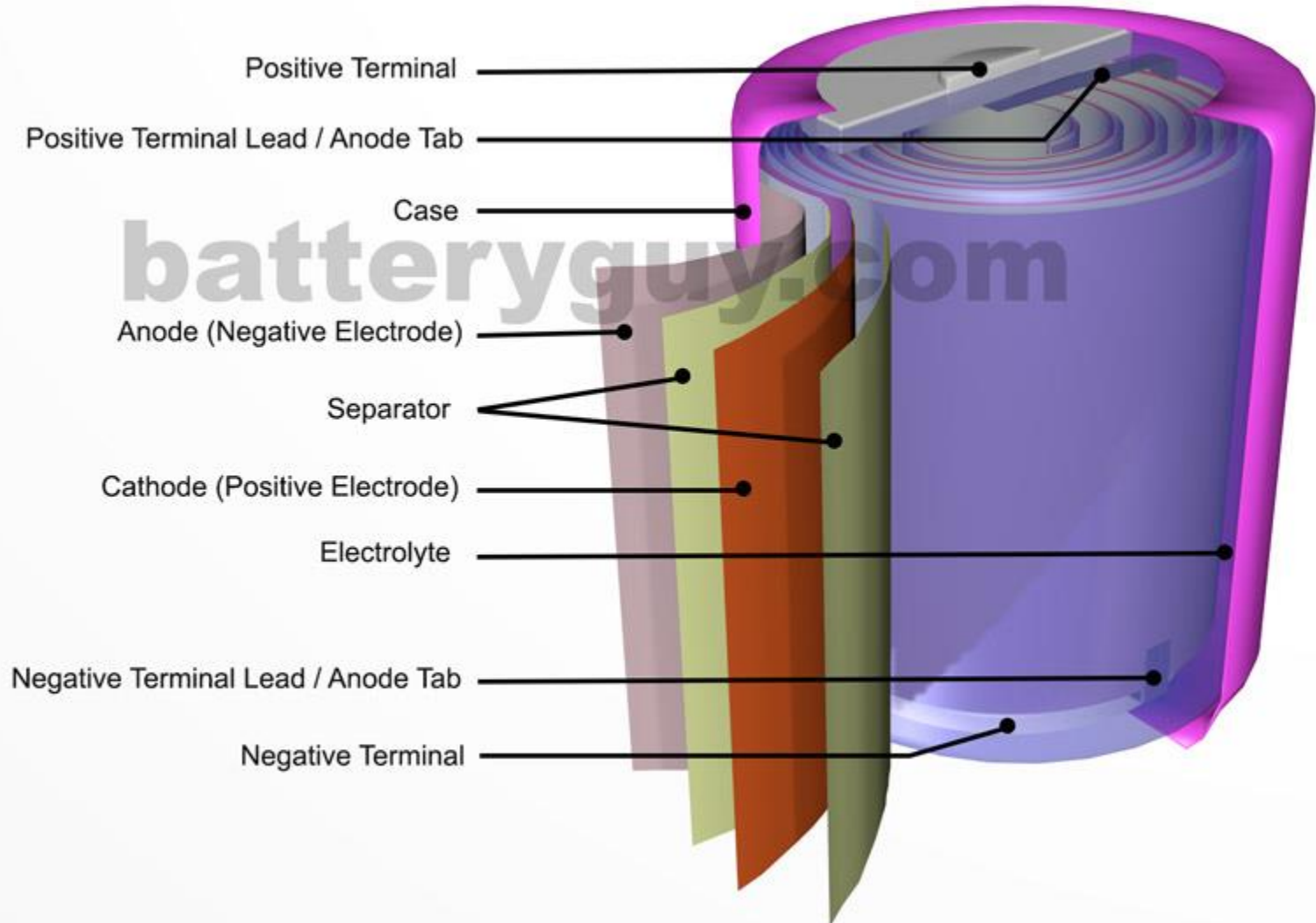

Source- batteryguy.com

*Sizes, spacing and colors for illustration purposes only.*



## ❑ Shapes and sizes

- One of the assets which sets lithium batteries apart, is the incredibly thin width of the plates and separator – sometimes less than half that of a human hair. This means they can be wound into a large number of shapes that are small enough to fit in a credit card or brick sized to power larger appliances.
- This micro technology also makes it possible to create batteries which can quite literally bend and flex, although costs mean much of this is reserved for rechargeable lithium-ion batteries



*Lithium batteries can be small and thin enough to fit inside a credit card*



## ❑ **Safety devices built into lithium batteries**

- The previous image (Basic structure of a lithium cell battery) shows the essential elements needed for a lithium battery to operate.
- However manufacturing defects, abuse or incorrect charging can cause lithium batteries to overheat to such an extent that they can catch fire or explode.
- Reputable manufacturers have recognized the need to add elements within the battery which can reduce these hazards. The image below shows some of the most common additions.

Lithium Cell Battery Positive Terminal Elements

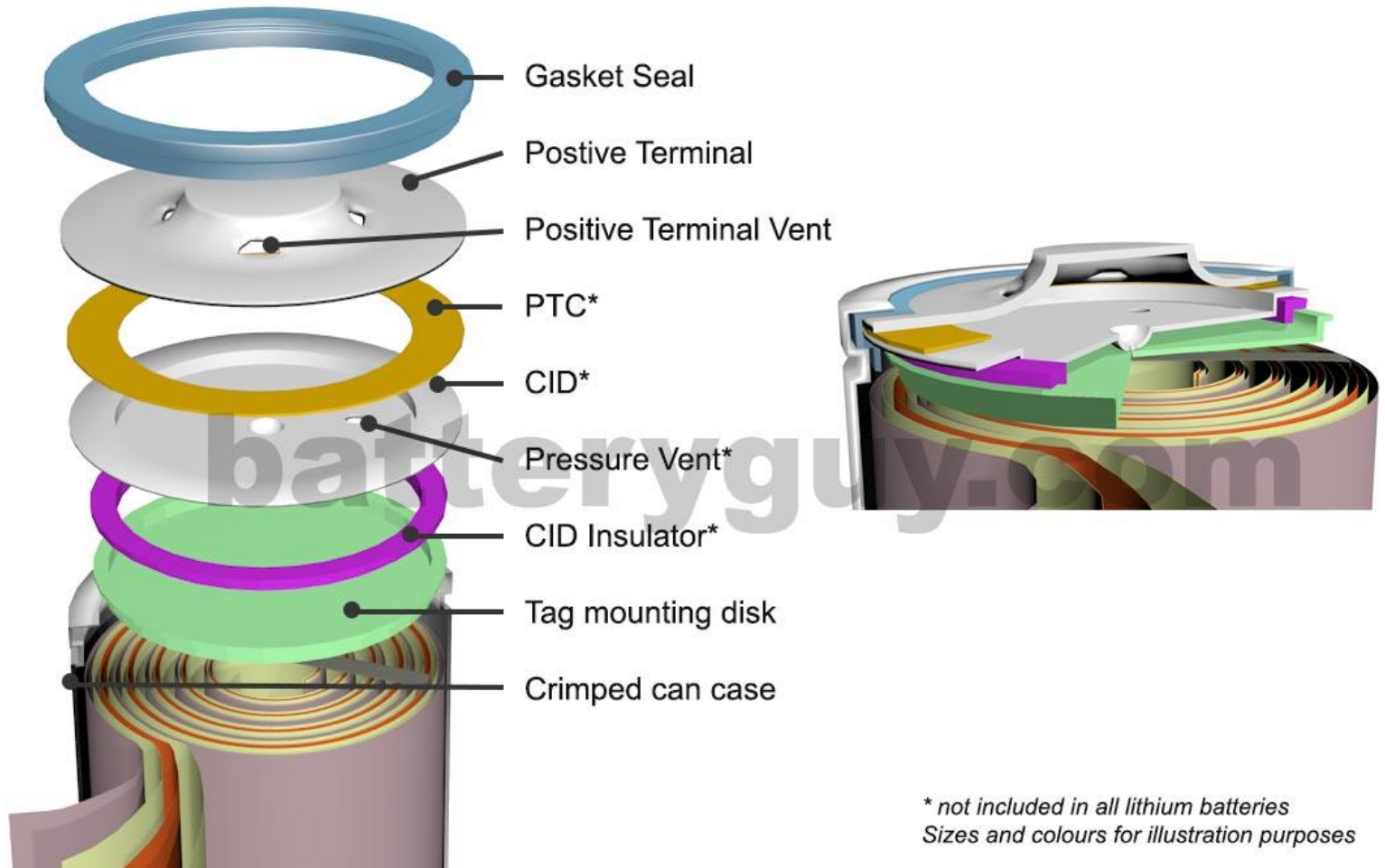

Source- batteryguy.com



- **Gasket Seal** – the negative terminal is often connected directly to the battery case in effect making the entire battery case the negative terminal. The gasket seal separates the case from the positive terminal
- **Positive Terminal Vents** – these are simply holes in the positive terminal to let out any gases that are released by the pressure vent in the CID (see below)
- **PTC (Positive Temperature Coefficient** also sometimes referred to as the “**Pressure, Temperature, Current Switch**“) – if the battery becomes excessively hot this material increases in resistance effectively cutting the positive terminal off from the battery.
- **CID ( Circuit Interrupt Device )** – a metal alloy element that changes shape when the temperature rises above a certain point and by doing so cuts the positive terminal off from the battery.





- **Pressure Vent** – malfunctioning batteries can generate large volumes of hot gases which, if not released, can cause fire or an explosion.
- **CID Insulator** – makes sure the tag mounting disk does not touch the Circuit Interrupt Device anywhere except at the point designed to change shape at high temperatures.
- **Tag mounting disk** – ensures a strong connection with the positive tab.





## ❑ Pros and Cons of a Lithium Battery

### ■ Pros

- Can deliver high energy fast to devices such as cameras.
- Can operate at extreme temperatures from  $-40^{\circ}\text{F}$  ( $-40^{\circ}\text{C}$ ) to  $140^{\circ}\text{F}$  ( $60^{\circ}\text{C}$ ).
- Very long shelf life when not in use – up to twenty years on some household applications such as smoke alarms.
- Long lasting in slow drain applications – up to fifteen years for specialized medical uses such as pacemakers.
- Lighter than other batteries with comparable power.
- Consistent power



## ■ Cons

- Expensive to produce.
- Travel and shipping restrictions by air.
- Difficult to recycle.
- Low on demand power (e.g. recharging a camera flash fast)

## ■ Further Reading- [Shipping lithium batteries](#)

# ❑ Manufacturing Process of Lithium Battery

## How a Lithium battery is made

Wafer thin anodes (negative), cathodes (positive) and porous separator sheets are manufactured



These sheets are wound together<sup>1</sup>. Metallic tabs are connected to the anode and cathode sheets



The sheets are so thin that they can be wound into a large variety of shapes and sizes and the tabs attached in different locations

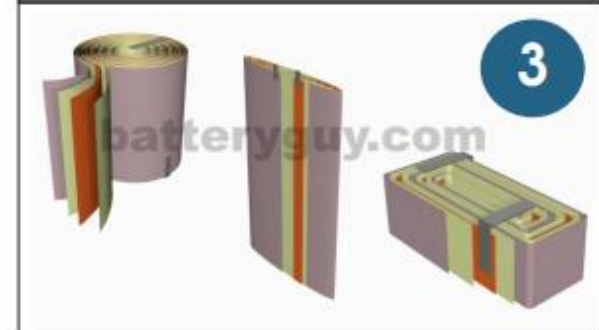

The case can be metallic, a soft foil or hardened plastic depending on the final applications requirements



Electrolyte which allows chemical reactions between the anode and cathode is added<sup>1</sup>

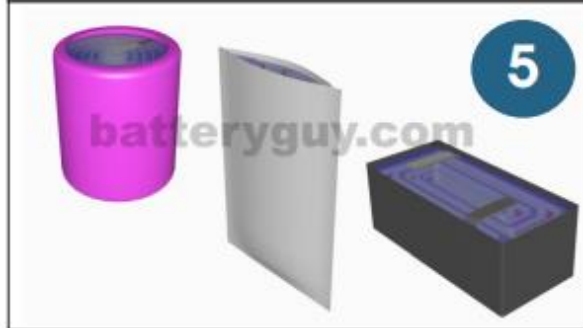

The positive and negative terminals can be plates, wire leads or tabs

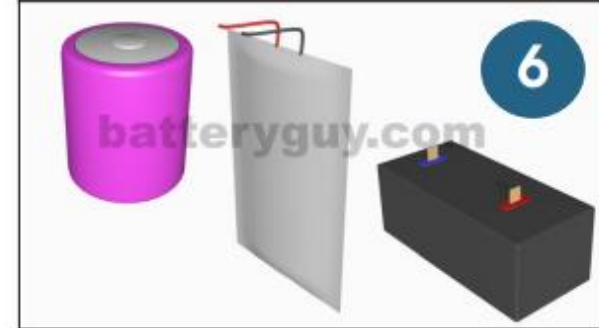

<sup>1</sup>In some manufacturing processes the separator is soaked with electrolyte before being wound



## ■ Further Reading-

[How Lithium Polymer Batteries are Made](#)



## ❑ Evolution of Lithium-Ion batteries

- Since 1991 six types of Lithium-Ion battery types have entered the mainstream market:
  - 1991 – **Lithium Cobalt Oxide** (Li-cobalt or LCO ) – with an energy to weight ratio of 150-200Wh/kg this is the battery of choice for smart phones, laptops and cameras even though they cannot be fast charged and have a short lifespan.
  - 1996 – **Lithium Manganese Oxide** (Li-manganese or LMO) – a safer battery but with a shorter calendar and cycle life. However it is better at delivering high current, making it popular in electric vehicles and power tools.
  - 1996 – **Lithium Iron Phosphate** (Li-phosphate or LFP) – a very safe battery, even when abused, with a long cycle life and the ability to produce high currents, but the shortest calendar life of lithium-ion batteries. Often used as a replacement to starter batteries in hybrid cars or cars fitted with engines that shut down when stationary.



- **1999 – Lithium Nickel Cobalt Aluminum Oxide (Li-aluminum or NCA)** – offers an outstanding energy to weight ratio, but costly to produce and with a very short cycle life it is mainly limited to specific industrial and medical applications.
- **1999 – Lithium Titanate ( Li-titanate or LTO)** – has excellent discharge capabilities and operates well at low temperatures (up to 80% capacity at  $-22^{\circ}\text{F}$  ( $-30^{\circ}\text{C}$ ), but high manufacturing costs and a low energy to weight ratio limit its use to certain types of Uninterruptible Power Supplies (UPS) and solar powered applications such as street lighting.
- **2008 – Lithium Nickel Manganese Cobalt Oxide (NMC)** – a long lasting battery that can produce the high power needed for power tools and smaller electric vehicles, but with a mid-range energy to weight ratio



- While chemistries can vary, so can the actual physical construction of the battery, as can be seen in the manufacturing process above. The three most well known types are:
  - **Cylinder** – the plates are wound into a circular shape (known as the jelly roll or Swiss roll) with terminals on the top and bottom.
  - **Can** – the plates are wound into a semi-rectangular shape so the battery can be wide, but flatter than a cylinder for use in applications such as cell phones and tablets.
  - **Pouch** – the plates are placed in a flexible foil container that can often literally bend to fit complex spaces.
  - Thus, one of the most important advantages Lithium has over many other battery types is its ability to be manufactured into specific shapes or even structures that do not have a solid shape and can flex as required without damaging the internal components.





## ❑ Comparison of Lithium-Ion battery types

- There are two key types of Lithium-ion batteries:
  - **Cobalt based** – excellent at delivering low energy over long periods. The chemistry of choice in cell phones, laptops, cameras, etc.
  - **Manganese based** – better at delivering high current fast and so used for applications such as power tools and electric vehicles. When used in applications such as laptops however, they last half as long as their cobalt counterparts.
  - Further Reading- [Detailed Comparison of Li-ion Batteries](#)



■ Lithium-ion development has centered around trying to find one cell that could cover both long discharges as well as high energy on demand by adding metals such as iron, aluminum and nickel.

Type	Voltage (operating range)	Specific Energy	Specific Capacity	Cycle Life	Calendar Life	Fast Charge
Lithium Cobalt Oxide	3.6 (3 – 4.2 volts)	150-200 Wh/kg	140 mAh/g	500 – 1,000 <sup>1</sup>	? <sup>2</sup>	No
Lithium Manganese Oxide	3.7 (3 – 4.2 volts)	100-150 Wh/kg	125 mAh/g	300-700 <sup>1</sup>	? <sup>2</sup>	Yes
Lithium Iron Phosphate	3.2 (2.5 – 3.6 volts)	90-120 Wh/kg	134 mAh/g	1,000 – 2,000 <sup>1</sup>	? <sup>2</sup>	? <sup>2</sup>
Lithium Nickel Cobalt Aluminum Oxide	3.6 (3 – 4.2 volts)	200-260 Wh/kg	180 mAh/g	500 <sup>1</sup>	? <sup>2</sup>	? <sup>2</sup>
Lithium Titanate	2.4 (1.8 – 2.85 volts)	70-80 Wh/kg	150 mAh/g	3,000 – 7,000	15 years	Yes
Lithium Nickel Manganese Cobalt Oxide	3.6 (3 – 4.2 volts)	120-220 Wh/kg	200 mAh/g	1,000 – 2,000 <sup>1</sup>	20 years	?

- <sup>1</sup> affected by temperature and the depth of discharges
- <sup>2</sup> too early to tell with any real confidence

Source- batteryguy.com



- While there appear to be clearly superior options in terms of capacity (energy/weight ratios) and life cycles, engineers also need to take into account other factors such as safety, number of cycles, or the batteries ability to fast charge.
- As such, which battery to choose depends greatly on the requirements of the device.
- A battery for a pacemaker for example, needs to deliver consistent energy, last a long time and be safe – these three requirements ranking far higher than other needs.



- However, the figures above should also be treated with caution, as different manufacturers using what they claim to be the same mix of chemistries produce batteries with different abilities.
- For example in March 2015, Andreas Gutsch of the Karlsruhe Institute of Technology published results of a test into Lithium-Ion life cycles and found that after 1,000 cycles, some cells lost up to 30% of their capacity – i.e. it was not possible to fully recharge them.
- Results varied by manufacturer and country of origin even though the battery types were theoretically identical.
- Further Reading- [Lithium-Ion Battery Life](#)



- In applications such as electric cars, this can make a big difference in terms of how far you can travel on one charge and how far you can travel over a batteries life cycle.
- A battery at full capacity may be able to power an electric car for 500 kilometers. At 70% capacity, that figure drops to 350 kilometers.
- Over several hundred charges and discharges, this adds up to a difference of thousands of kilometers.



- With this in mind, the following table ranks from ‘best’ at the top to ‘worst’ at the bottom based on lithium-ion battery types for a number of characteristics using data currently available and assuming the battery is sourced from a reputable manufacturer. Where more than one battery type is shown, this means that their performance is broadly similar.



Specific Energy	Specific Capacity	Cost	Safety	Cycle Life
Lithium Nickel Cobalt Aluminum Oxide	Lithium Nickel Manganese Cobalt Oxide	Lithium Cobalt Oxide	Lithium Titanate	Lithium Titanate
Lithium Cobalt Oxide	Lithium Nickel Cobalt Aluminum Oxide	Lithium Manganese Oxide	Lithium Iron Phosphate	Lithium Nickel Manganese Cobalt Oxide
Lithium Nickel Manganese Cobalt Oxide	Lithium Titanate	Lithium Nickel Manganese Cobalt Oxide	Lithium Manganese Oxide	Lithium Iron Phosphate
Lithium Manganese Oxide	Lithium Cobalt Oxide	Lithium Iron Phosphate	Lithium Nickel Manganese Cobalt Oxide	Lithium Cobalt Oxide
Lithium Iron Phosphate	Lithium Iron Phosphate	Lithium Nickel Cobalt Aluminum Oxide	Lithium Nickel Cobalt Aluminum Oxide	Lithium Manganese Oxide
Lithium Titanate	Lithium Manganese Oxide	Lithium Titanate	Lithium Cobalt Oxide	Lithium Nickel Cobalt Aluminum Oxide



# POPULAR LI-ION BATTERY CHEMISTRIES

**Lithium-nickel-cobalt-aluminum (NCA)**

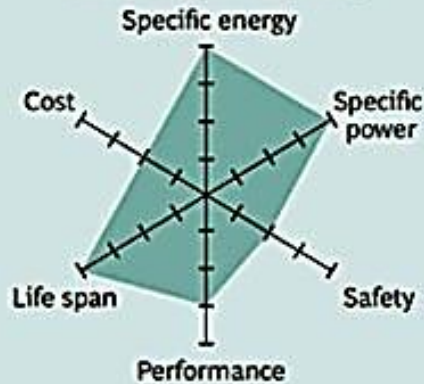

**Lithium-nickel-manganese-cobalt (NMC)**

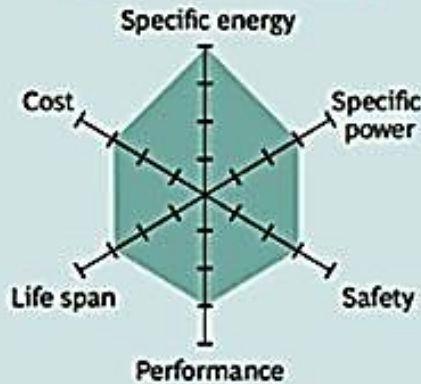

**Lithium-manganese spinel (LMO)**

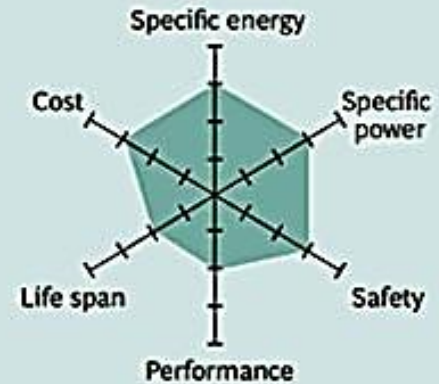

**Lithium titanate (LTO)**

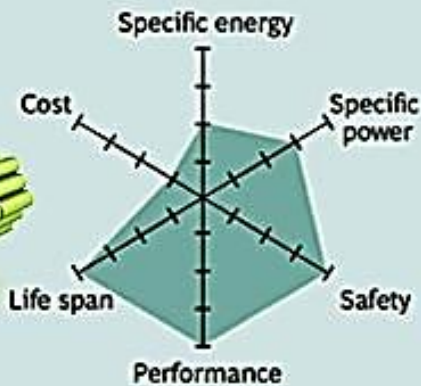

**Lithium-iron phosphate (LFP)**

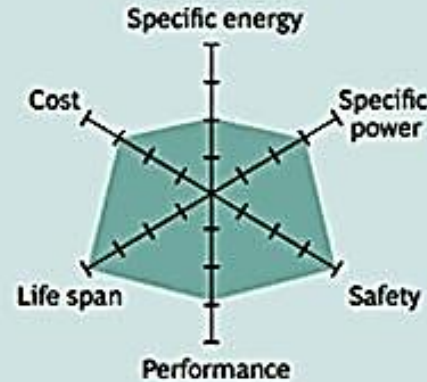

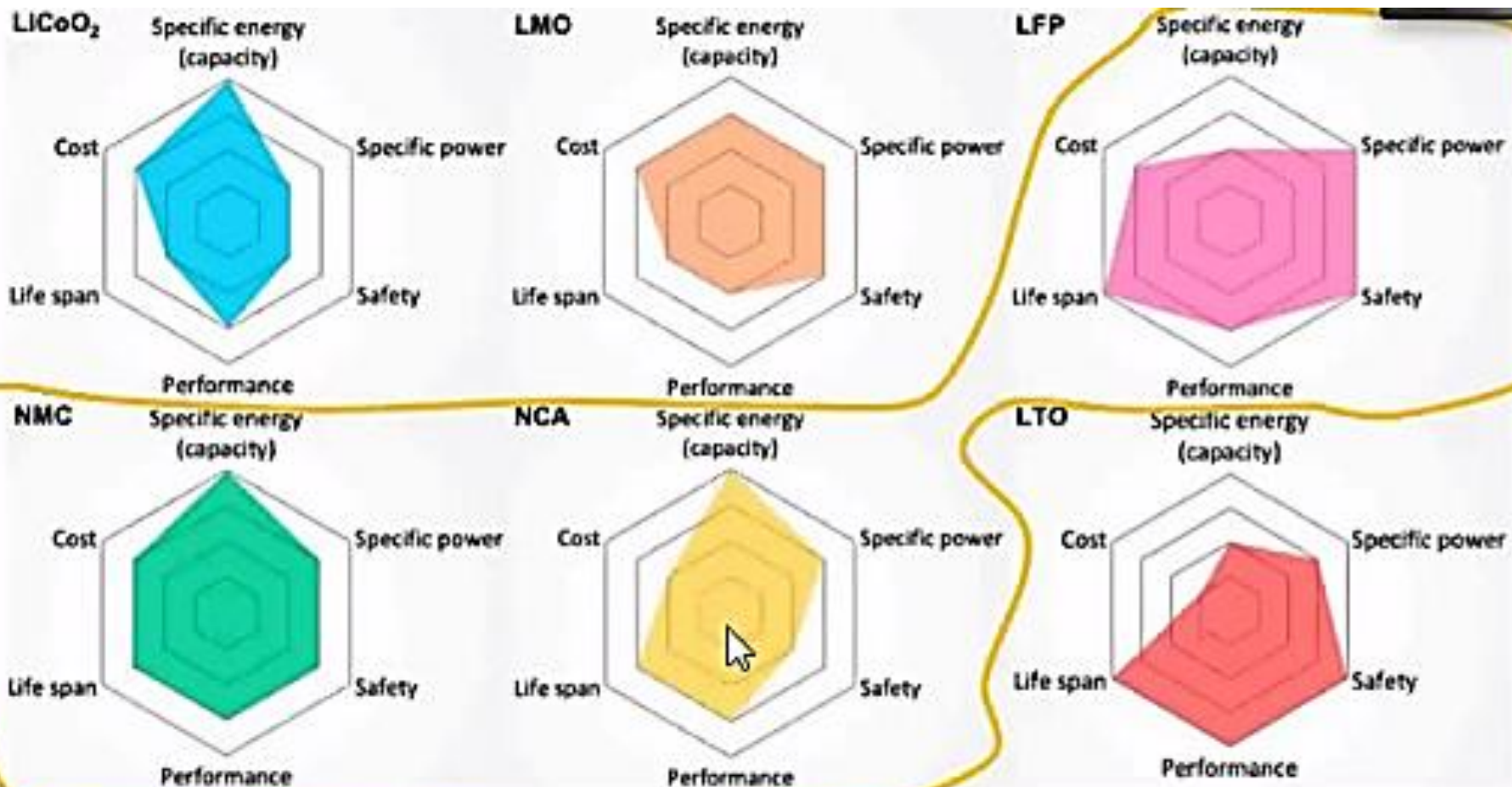



## ❑ Lithium-Ion versus other battery chemistries

- When lithium metal (disposable) batteries first became commercially available in the 1970s, most portable devices were powered by nickel cadmium batteries. Rechargeable lithium-ion batteries did not make their debut until the early 1990s, but since then they have not stopped evolving.
- They have a number of advantageous over other battery chemistries:
  - they can store over four times as much energy as lead acid batteries and twice as much energy as nickel based.
  - not only can they store more, they can do it in less space giving them double the energy density of nickel cadmium.
  - they are low maintenance and easier to store with a much smaller self discharge rate than nickel cadmium.
  - a lithium-ion cell produces 3.6 volts, three times higher than the nickel cadmium cells 1.2 volts.
  - from an environmental point of view, they are less damaging if disposed of incorrectly



- But it is not all a one way street. Lithium-ion has been plagued by safety issues. Most notably thermal runaway – when a cell shorts out or is incorrectly charged, extreme heats are generated which can start fires.
- As such, modern Lithium-ion cells must be fitted with features which add to weight and cost. Given that, lithium was already a more expensive battery compared to nickel cadmium. These requirements now make it nearly 50% more costly to manufacture.
- The thermal runaway issues have also lead to the introduction of air travel restrictions and shipping regulations which makes commercial shipping more of a headache





- The overall life of lithium-ion has also not been particularly encouraging with most not lasting more than 36 months.
- In many applications such as smartphones, where consumers frequently upgrade, this is not noticeable. With commercial or industrial applications and increasing usage in vehicles, this is a drawback.
- The technology remains fast moving with new types coming onto the market every year. Many have no track record regarding stability, calendar life and questionable cycle life abilities without losing capacity.

